

REDUCING BANDSAW TECHNOLOGY

EWD

ZE 2 Align and infeed system

- Scan
- Optimise
- Rotate
- Align
- Chip

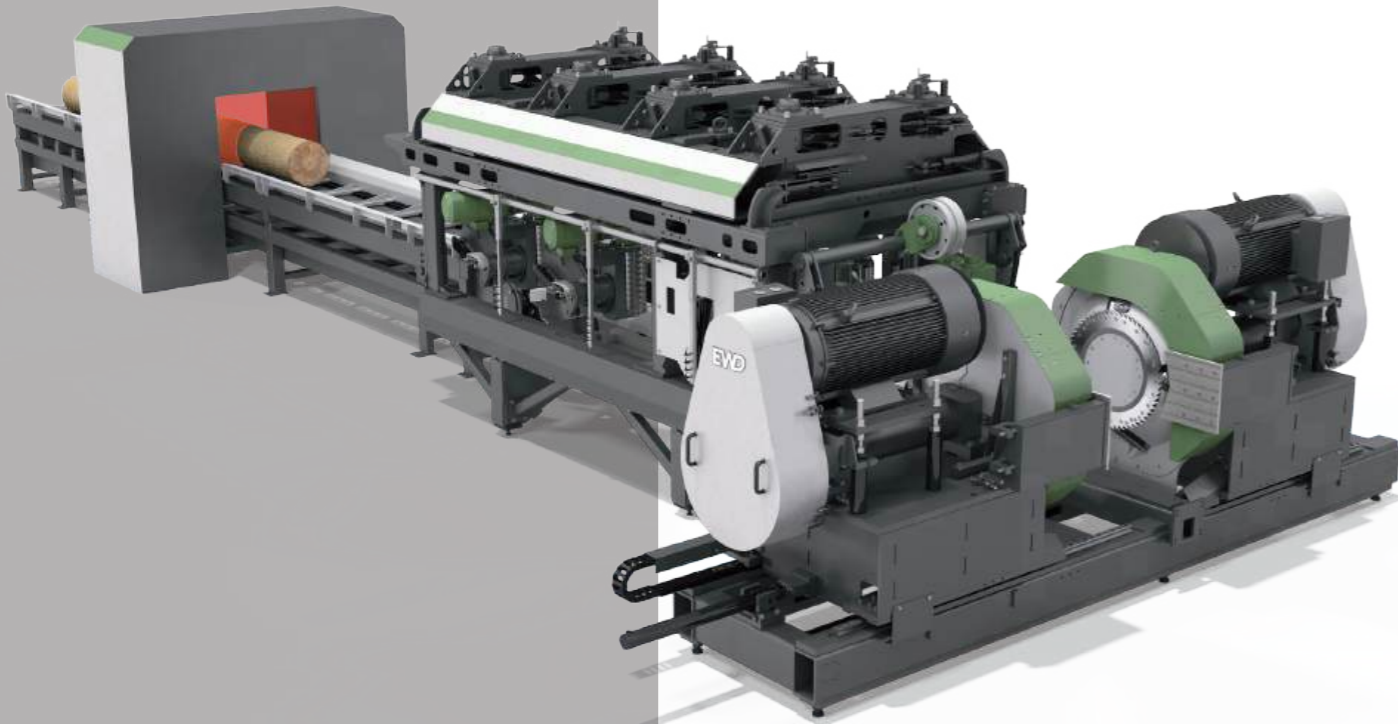

The completely new designed align and infeed system ZE 2 with top-mounted skewing frame and top activated roller pairs offers many advantages:

- The modular design allows the optimum adaption to the requirements of all kinds of log and two-sided cant infeed systems in modern industrial sawmills.
- Easy deflection of bark and broken lumber pieces as well as dirt and ice.
- Easy access for routine checks and maintenance works.
- Easy change of transport chains and rollers.
- Less cleaning required, in particular of movable components.



Use your phone or tablet to scan this QR Code and see the Quadroline in action.

ZE 2 Aligning and positioning



Logs can be rotated very precisely in their required orientation, following a 3D true shape scanning and optimization, at highest feed speeds and with minimum log gap.

The logs are positioned either to machine center line, parallel side shift or diagonally to the machine center line (skew), depending on their shape and sweep.

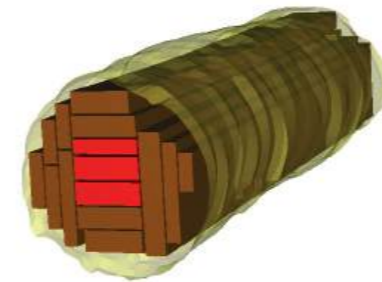

The cant alignment is done based on 3D scanning and sawing pattern optimisation, again parallel to the machine center line or diagonally to the machine center line (skew). The ZE 2 allows increasing the recovery by sawing of logs and cants with asymmetric cutting patterns to get the most out of them.

Only two servo-hydraulic networks are required to perform optimised log and two-sided cant orientation with skew and shift in straight sawing mode.

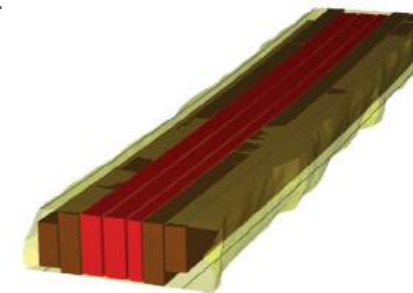

Curve sawing mode by means of a skewing frame with servo axes.

OPTIONS:

- FZ 1 chipper canter
- Small end position corrections
- 4-sided cant turning device



TECHNICAL DATA

Log/cant length	m	from 1.8
Minimum small end diameter	mm	100
Max. log diameter	mm	750
Cant height	mm	60–500
Max. opening of rollers	mm	780
Feed speed	m/min	up to 200
Max. side shifting/skew	mm	+ / - 90
Sweep for active curve chipping	mm/m	10
Weight of standard infeed table and log length max. 6m	t	16

PF 19
Universal chipper canter



→ For medium to large Reducing and Profiling lines

The chipper canter PF 19 is used in Circular Saw or Reducer Bandsaw lines and also in Profiling lines for chipping of two parallel faces on logs or cants. The width adjustment of the chipper head supports is done by servo-hydraulic networks.

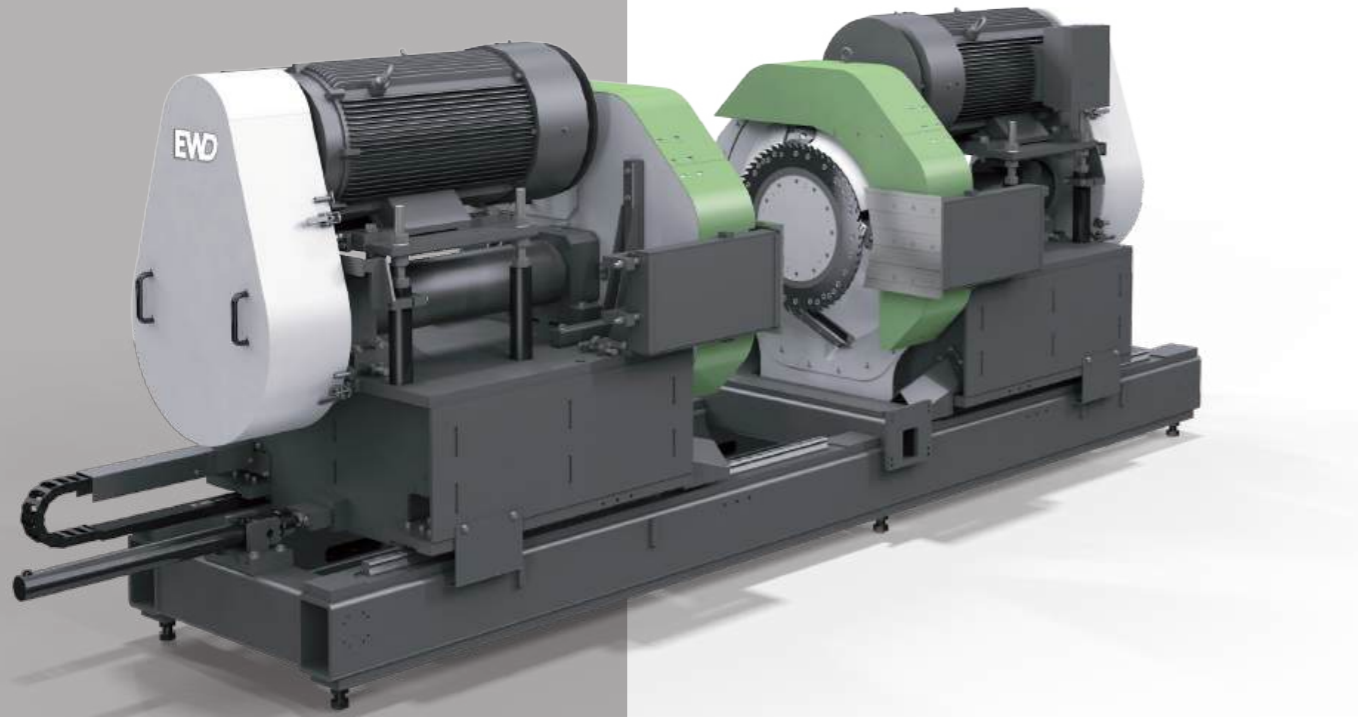

The produced chips meet the high quality requirements of the pulp industry.

The chipper head revolutions are controlled by a frequency converter as a function of feed speed and desired chip lengths.

Sliding platform for easy and safe access for tool change and maintenance.

CHIPPER HEAD
Straight knives / Spiral knives

Optionally, the chipper canter PF 19 can be fitted with either straight knives, spiral knives or stepped knives heads.

The different head types are matched by the number of tools installed to the desired speed range.

All heads are fitted with either pre- or post-sawing circular saw rings, depending on the purpose.

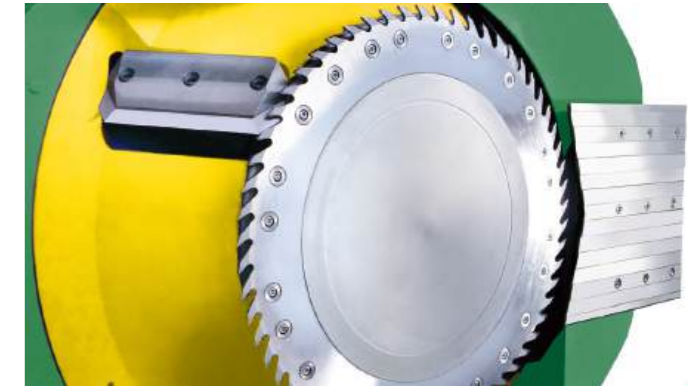

TECHNICAL DATA PF 19

Chipper head diameter		
Straight knives chipper head	mm	1240
Spiral knives chipper head	mm	1260
No. of main knives (straight knives head)	pcs.	3, 4, 6
No. of spirals (spiral knives head)	pcs.	3, 4, 5
Chipping depth per head max.		
Straight knives chipper head	mm	190
Spiral knives chipper head	mm	180
Chipping height above chain bed max.		
Straight knives chipper head, pre-sawing	mm	612
Straight knives chipper head, post-sawing	mm	505
Spiral knives chipper head, pre-sawing	mm	580
Spiral knives chipper head, post-sawing	mm	540
Distance between the chipper heads in operation	mm	60-700
Opening side for tool change	mm	900
Feed speed	m/min.	20-150
Drive power	kW	2x75 - 2x250 (at 1500 1/min)
Weight with drive motors (2x250kW)	t	13.0

QUADROLINE

Reducing - Bandsaw technology

- high yield
- flexibility
- high efficiency

The demanding job of the saw filing of bandsaw blades is now done by a new generation of automatic stellite-tipping, grinding-, levelling and tensioning machines with highest reliability.

New bandsaw steel qualities allow longer hours of operation with even thinner blade thickness.

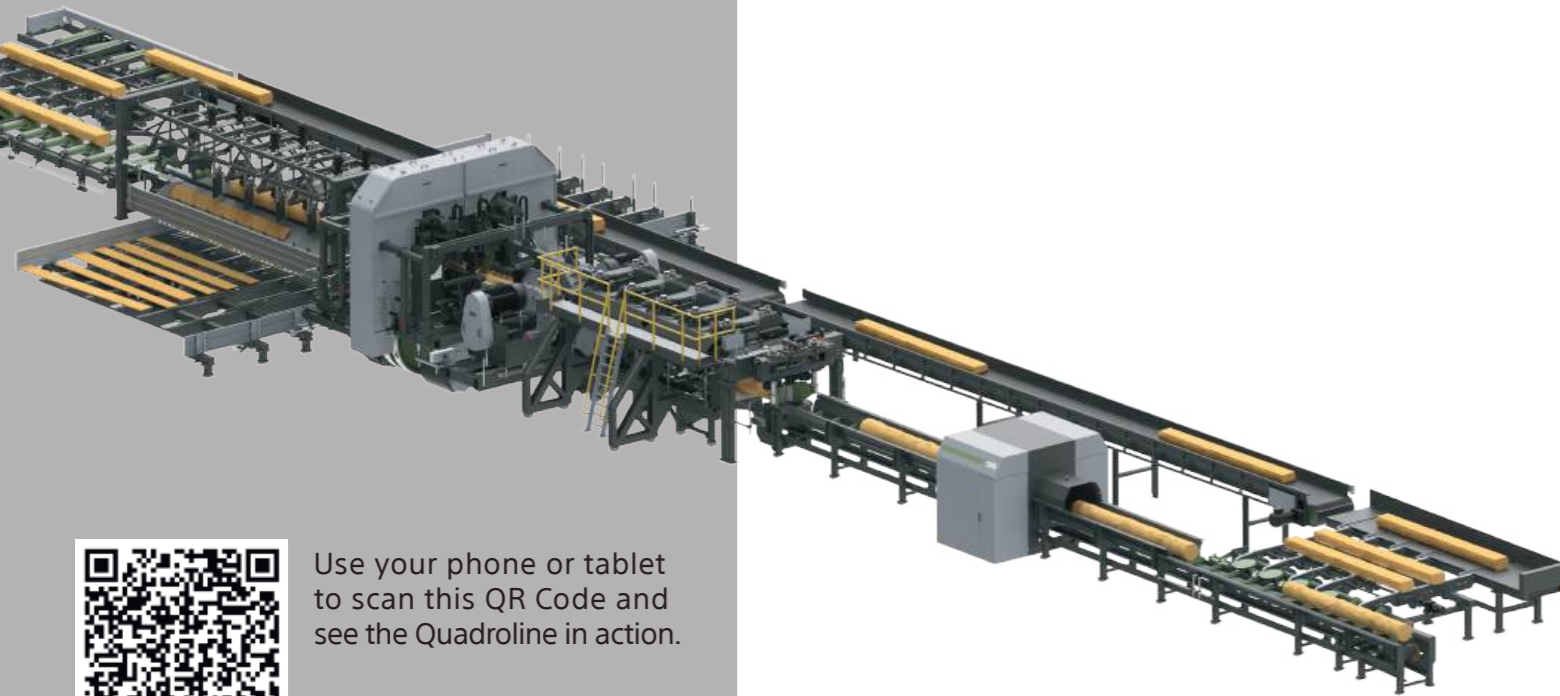

Use your phone or tablet to scan this QR Code and see the Quadroline in action.

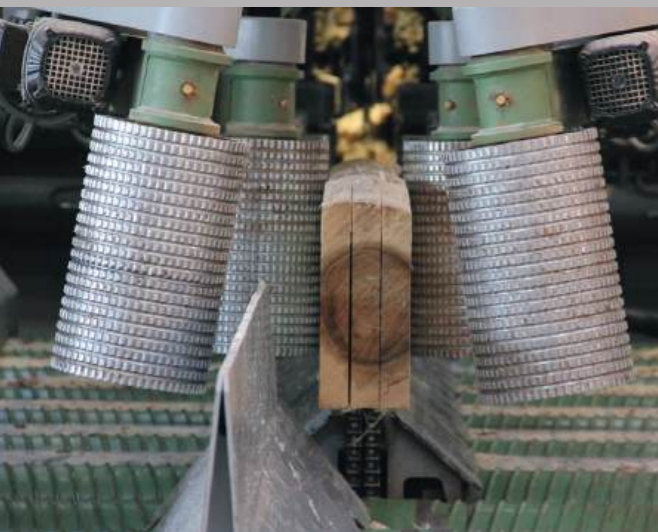

QUADROLINE

Large sawing heights with minimal saw kerf



The reducer bandsaw allows to process large sawing heights with a minimum saw kerf. The positioning of the saw kerfs and therefore the production of any lumber size required is basically unlimited.

Frequency controlled speed drives for the sawing speed allow the adjustment of the sawing process to fit the different cutting conditions.

With the modular design of the EWD Bandsaw Technology every conceivable task in today's sawmill industry can be solved.

The combination of bandsaw, circular saw and canter technology is almost without limits.

With feed speeds in excess of 120 m/min, the reducing bandsaw technology not only satisfies highest recovery requirements, but also the need for high throughput.



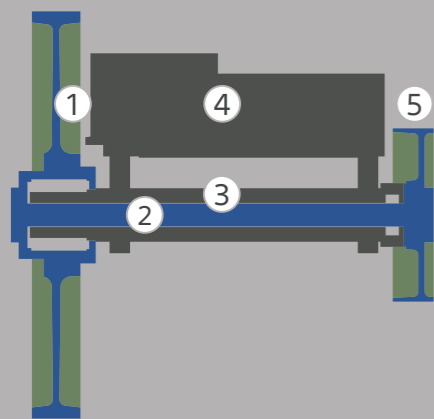

THE BANDSAW WHEELS

Due to the high stresses, both wheels are made from high quality spheroid graphite iron. The surface hardness of this material allows years of operation without needs to regrind the wheels. The design of the wheels has been optimized by sophisticated, computer-assisted calculation methods. The bottom wheel with its considerably higher momentum always “pulls” the blade through the log.

THE ROLLER INCLINATION

For an accurate adjustment of the bandsaw on the wheels, the inclination of the top wheel can be set by means of an electric motor.

THE SAW STRAIN SYSTEM

The sawing accuracy of a bandsaw depends heavily on the bandsaw strain system. The EWD bandsaw strain system offers a very fast reaction time and instantaneous shock absorption. One short-stroke, quick-reaction hydraulic cylinder provides strain, which can be adjusted infinitely up to a maximum saw strain of 200 N/mm². The saw strain is then automatically kept constant, even when encountering different sawing loads, such as changing log density or knots.

THE WHEEL BEARINGS

The saw strain is directly transferred to the machine frame by utilising the dead arbour concept. the drive shaft is thereby not loaded with bending stresses.

Advantage: minimum bearing wear, highest precision and smooth running.

- ① bottom wheel
- ② drive shaft
- ③ dead arbor
- ④ machine frame
- ⑤ drive pulley

THE SAW BLADE GUIDES

The blade guides are pressure guides, pushing the saw blade out of the vertical plum line in the cut. To avoid any collision between clamped log and the saw blade during the return move of the carriage for the next cut, the entire bandsaw-headrig with the saw is pulled hydraulically away from the cut position, controlled by a mechanically adjustable initiator sensor. The top saw guide is moved on precision linear bearings, with a hydraulic cylinder adjusting the height. The bandsaw is set on guides and can be fitted optionally with a servo-hydraulic network. Thus the maximum opening between headblock and bandsaw can be increased up to 1400mm for oversize logs.



FBS FLYING BANDSAW

Active saw guide system using intelligent magnets

For very high demands on performance and sawing accuracy, we use the active saw guide system FBS with intelligent magnets. The advantages:

- Relieving the saw blade of stress through conventional pressure guides allows the introduction of higher saw strain and higher saw speeds.
- Exact guiding of the saw blade in the saw track by the magnetic forces of the FBS technology enables significantly faster feed rates.

The results are

- constant accurate sizes
- notably higher production and recovery.

The FBS technology achieves excellent production results in summer and winter operation.



REDUCING BANDSAW TECHNOLOGY

Technical data

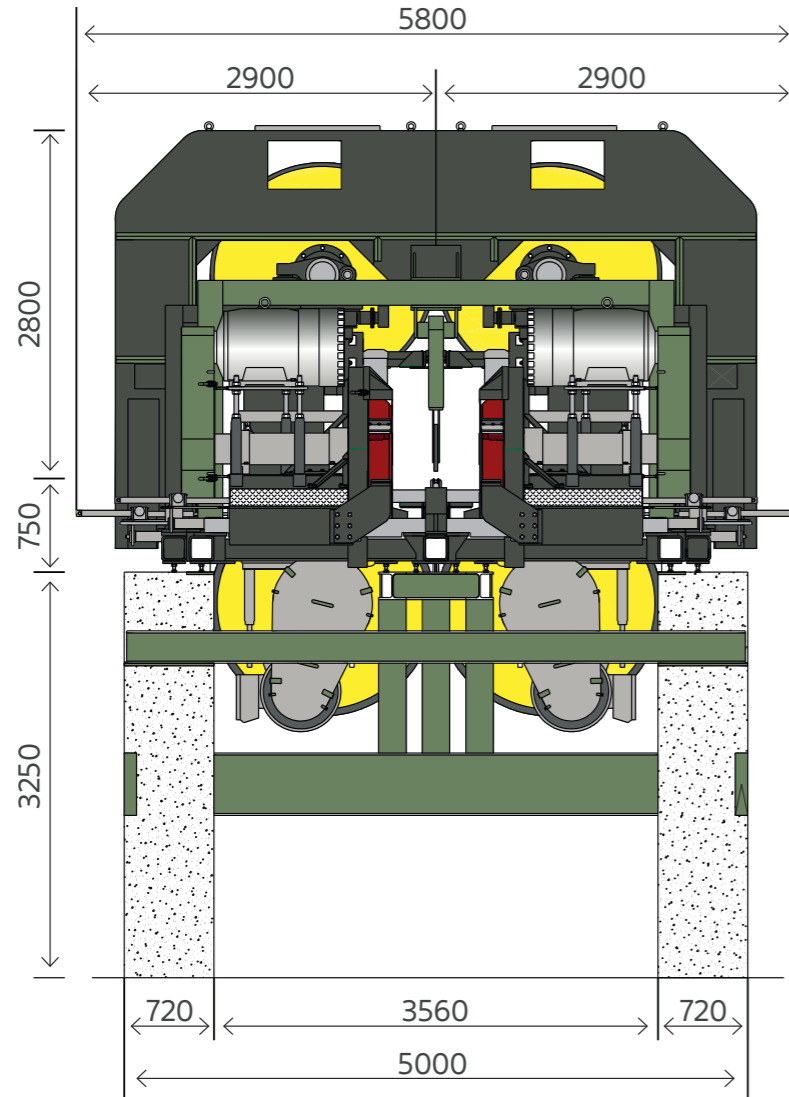

TECHNICAL DATA OF "MODUL"- BANDMILLS

TYPE		EBT1600	EBT1800
Wheel diameter	mm	1600	1800
Wheel face width	mm	190/230	190/210/230
Saw blade width	mm	206/250	206/230/250
Saw blade thickness max.	mm	1.65	1.83
Saw blade strain max.	N/mm ²	200	200
Drive motor size	kW	75-110	90-132

eWOOD

Optimization and application software



eWood is a comprehensive optimisation and application software from EWD. All modern EWD sawlines and machines share the same eWood user interface.

The interface man - machine offers an intuitive and consistent user concept, allowing effective use of the functions after just a short training period.

- Most modern measuring technology
- Professional optimisation and application software

In addition to solid and time-proven mechanical engineering, efficient system controls are essential prerequisites for the high efficiency and yield of the EWD Reducing Bandsaw Technology.

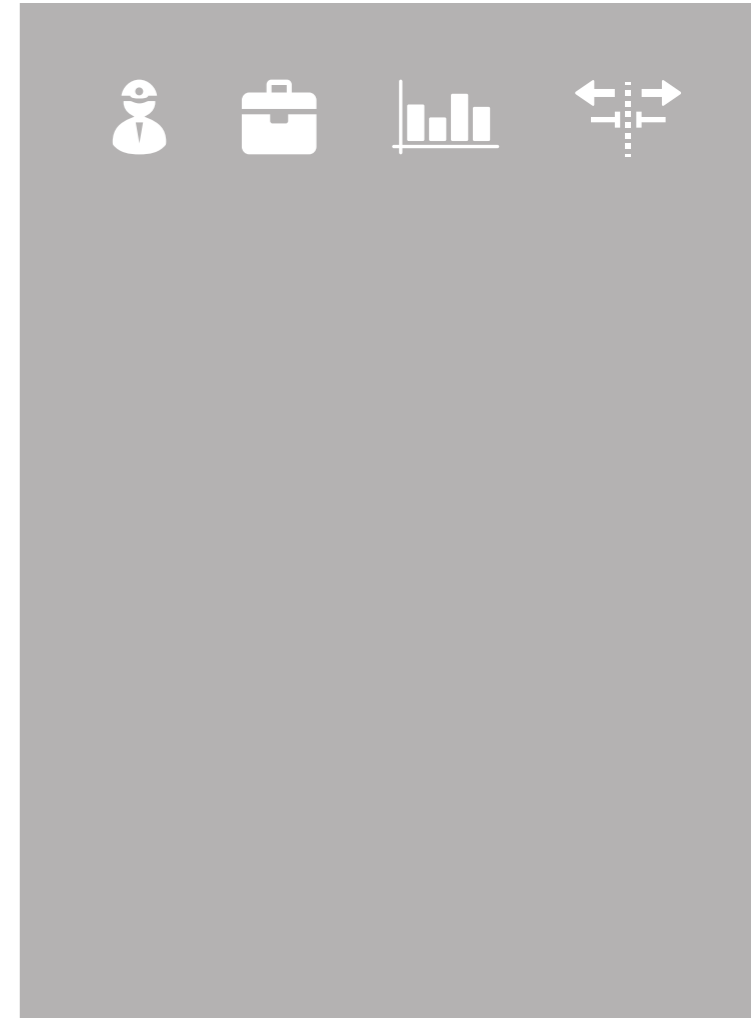

thickness	width	thickness	width	length	name	product type	lumber species	M-Value
22	95	22	100	2000-6300 (100)	22x100			£70.00
28	100	22	100	3000	22x100			£100.00
32		22	100	4000	22x100			£100.00
34								
48								
50								
60								
65								
70								
75								

REDUCING LINE WITH MERRY-GO-ROUND

Example 1



Compact reducer line with a Quad Bandsaw as the main break down machine.

In primary break down up to 4 side boards of variable thickness and one variable center cant thickness can be sawn.

In secondary break down up to 5 products of variable thickness can be sawn. The example shows a flexible double arbor circular saw DWK supplementing the Quad bandsaw for cant resawing.

Feed speed range from 25 to 120 m/min.
Length of the reducing line: approx. 56m

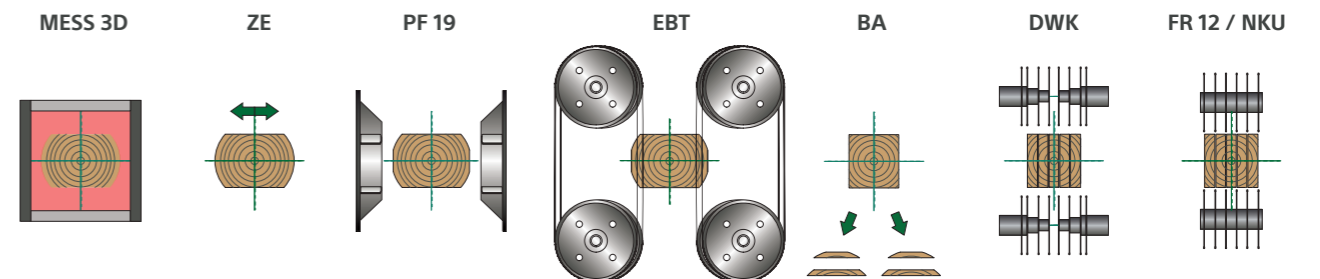
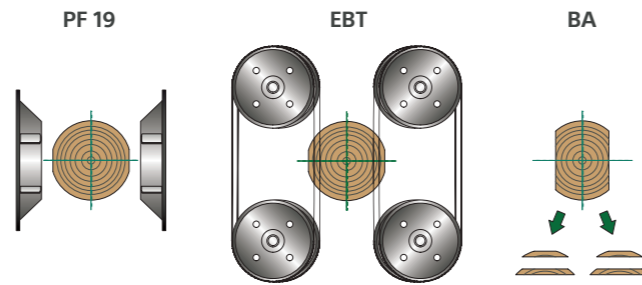
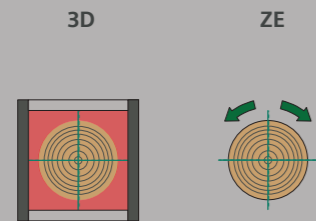

REDUCING LINE WITH MERRY-GO-ROUND

Example 2



Reducer line with two Quad Bandsaws as the main break down machines.

In primary break down up to 4 side boards of variable thickness and one variable center cant thickness can be sawn.

In secondary break down up to 5 center products of variable thickness can be sawn. Smaller diameter logs can be sawn in a single pass. Large logs are sawn in a very flexible way, using the merry-go-round system.

The standard line is designed for log length from 2.5 to 6.0 m and a maximum log diameter of 75 cm, including taper and sweep.

Feed speed range from 25 to 120 m/min.
Length of the reducing line: approx. 85m

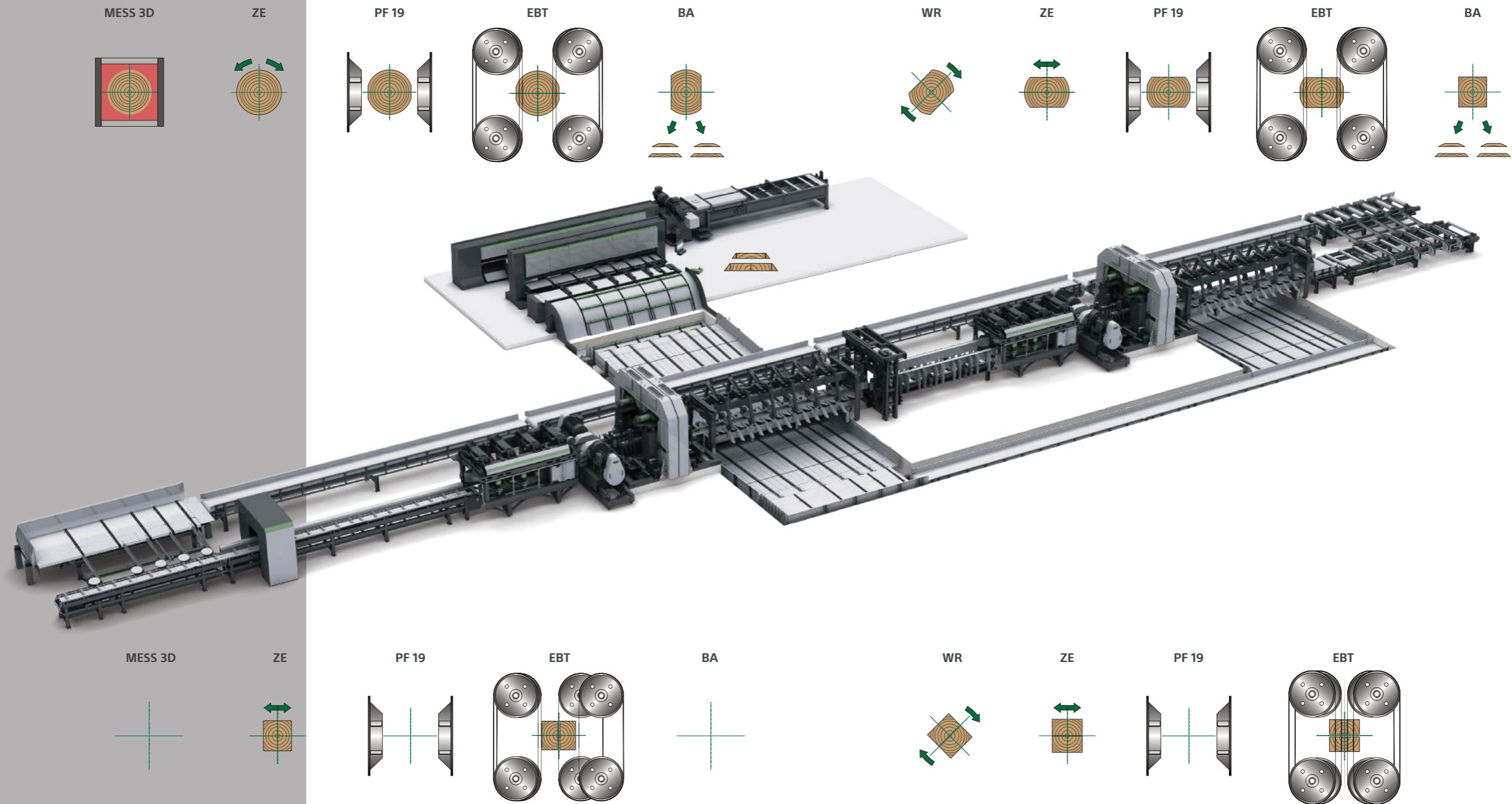

REDUCING LINE WITH MERRY-GO-ROUND

Example 3



→ Quad Bandsaw in primary break down.

Combined reducing and profiling line with separate resaw group for vertical and horizontal resawing.

For log length from 2.5 to 6.1m and a maximum log diameter of 75cm.

The line is designed for scan and set sawing, adjusting the tools from log to log. 5 center products of variable thickness for vertical resawing plus products sawn with the fix mounted saws, up to 3 products of variable thickness for horizontal resawing. In primary break down up to 4 side boards of maximum thickness 100 mm each can be sawn.

In secondary break down up to 2 side boards can be profiled up to a thickness of 45mm. Large logs can be sawn in secondary break down with up to 4 side boards, which will be sent to the optimizing edger system.

Length of the reducing profiling line: approx. 77m.

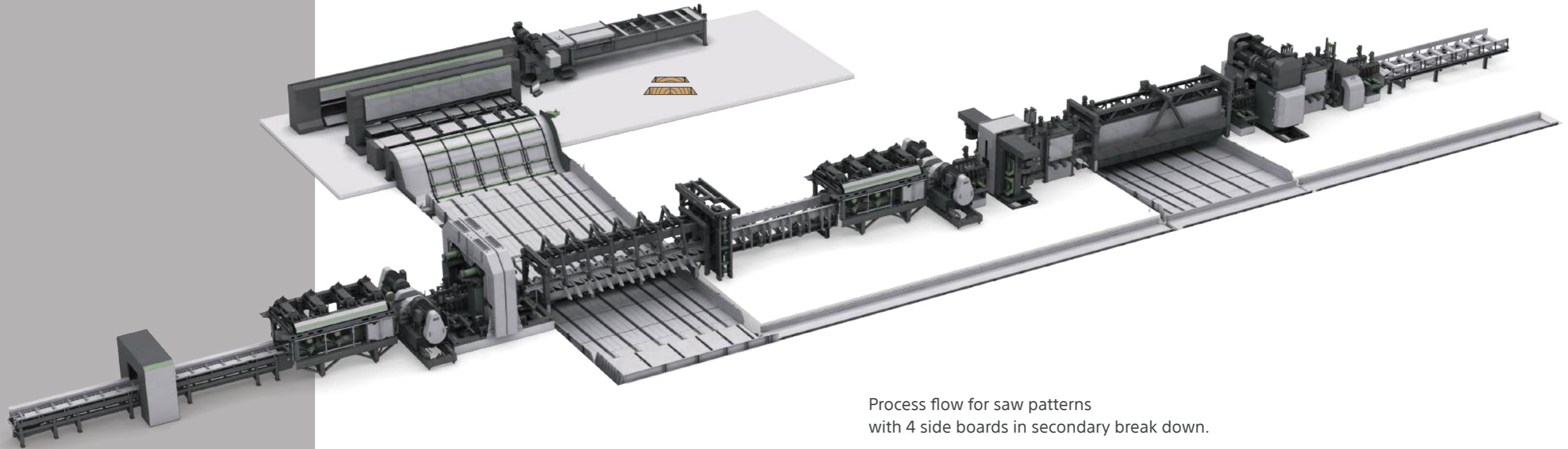
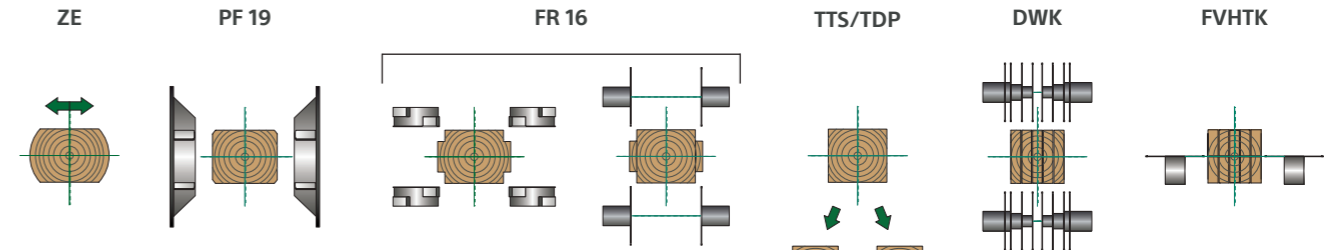
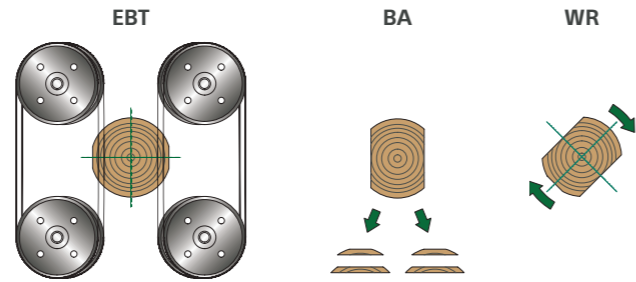
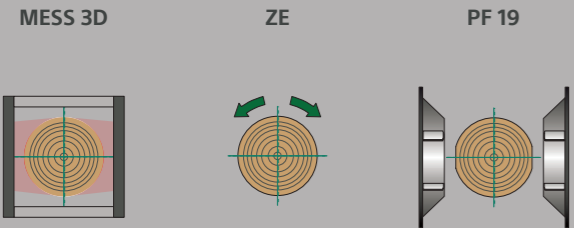

Process flow for saw patterns with 4 side boards in secondary break down.

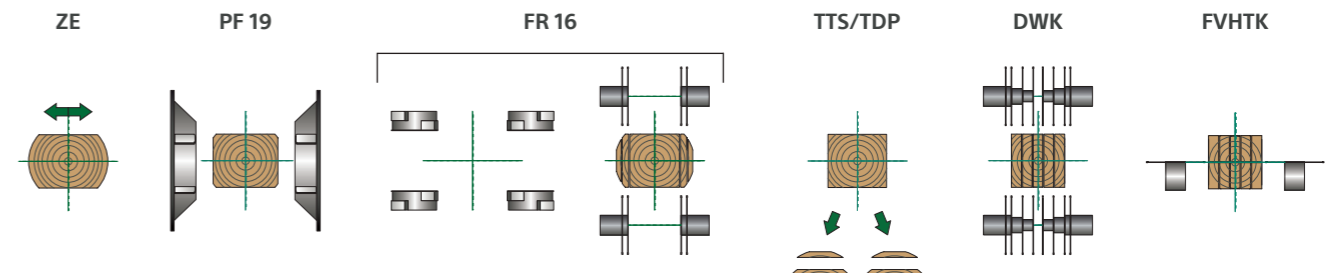
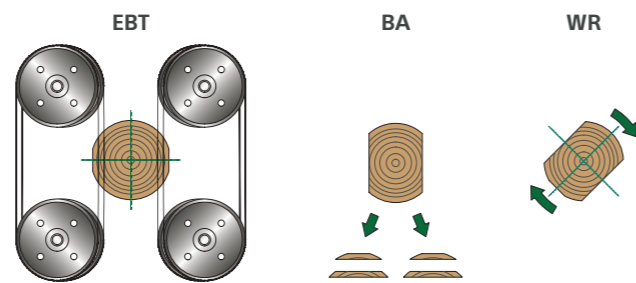
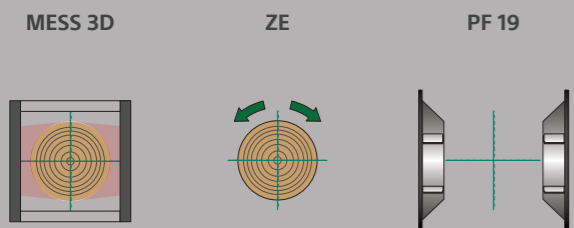

ROBOLINE

Universal bandsaw machine system

- Custom sawn timber
- Dimension products
- Live sawing



The RoboLine is a flexible cutting system for all saw patterns. The set time for a new saw pattern is extremely short. Slabs are automatically discharged before going to the edger system. Round logs or 2-sided cants are clamped on a driven carriage rail and fixed during the sawing process until cut direction is changed. This process provides a very good sawing accuracy.

No merry-go-round system for resawing is required. Log rotation and alignment of the log or cant are supported by the LiveView-System on the PC screen. There the saw pattern selected by the optimizing PC is displayed as well, which can be altered by the operator depending on the log quality. The recovery of the RoboLine is considerable better compared to similar circular saw systems because of the log alignment possibility along the log center line and the narrow saw kerf.



ROBOLINE

Flexible bandsaw system for all saw patterns



THE ROBOLINE IS DESIGNED AS AN UNIVERSAL MACHINE CENTER.

Example of universal sawing process



1. Aligning log



2. Sawing slabs



3. Sawing side boards



4. Sawing slabs



5. Sawing side boards



6. Resawing center product

TECHNICAL DATA OF THE BAND SAW UNIT "EBT 4-1600" WITH 4 MOVEABLE BANDMILLS

Type	EBT 4-1600	
Wheel face diameter	mm	1600
Wheel width	mm	190
Saw blade width	mm	205
Saw blade length	mm	approx. 10140
Driver motor size	kW	4 x 55-90
Log length	m	2-8 (12)
Log diameter	mm	100-800
Feed speed	m/min	up to 120
Feed speed return pass	m/min	up to 140



EWD

Esterer WD GmbH
Estererstraße 12
D - 84503 Altötting

T +49 8671 503 0
F +49 8671 503 386

Markwiesenstraße 40
D - 72770 Reutlingen

T +49 7121 5665 0
F +49 7121 5665 400

info@ewd.de