

**HIGH PERFORMANCE EDGER  
OPTIMIZER TECHNOLOGY**

**EWD**

# HIGH PERFORMANCE EDGER OPTIMIZER TECHNOLOGY

## OPTIMES



Use your phone or tablet to scan this QR Code and see the Optimes in action.

The edger optimizer system Optimes is a synonym for maximum yield in the performance class of 30–42 boards per minute. The versatility of this system comprises different board manipulation solutions, various scanning systems including grade scanning and the selection between different flexible top arbor saw units for almost all requirements.

Lumber infeed to the Optimes is possible from the left or right side and also from both sides.



## OPTIMES

Board unscrambling | Board trimming | Loading



### BOARD UNSCRAMBLING

Boards from the transfer conveyor are separated by an S-shaped chain cross conveyor. A rotating cam and a flipper kick out the leading board in case of a double occupancy of the conveyor bars. A faster running cross conveyor takes the board after the unscrambling process and feeds it to the grading and board handling station.

### GRADING AND BOARD HANDLING STATION

At this position, the operator can influence the further processing of a board, with the following possibilities:

- Input of a quality / grade information
- Decision for a specific board alignment
- Turning of a board to grade the 2nd face.
- Input of a trim back decision
- Activation of the drop-out gate for reject pieces
- Feed back to the board separator

### BOARD TRIMMING

A 0-line trim saw and driven feed rollers allow to trim back the fish tail end of a board by 0.5 – 1.5 m upon operator command to avoid further problems because of the slab end. For special applications the boards can be trimmed to a desired finished length or cross-cut into several short boards for packaging/pallet board production. These short boards are fed together into the edger infeed after trimming but are scanned and edged as individual boards.

### BOARD LOADING AND CENTERING ON THE INFEED TABLE

In front of the infeed table, optical sensors measure the contour and the thickness of the unedged board. Thereafter, the boards are automatically positioned either by program default or by operator command. They are either centered mechanically, positioned according to the usable area or aligned to the left or right side.

### LINEAR TRANSPORT

Pre-positioned top press rollers and a top hold down chain after the scanner provide a precise linear transport of the boards through the scanning system and up to the saws. Therefore, the scanning and optimization results are executed very precisely.



### → Precision scanning in linear mode

#### THE SCANNING SYSTEM

The precision scanning system consists of 2 cameras and 4 laser units for an optical scanning of board top and bottom side in linear mode. Turning of the boards before scanning is not necessary.

A configuration with quality scanner or X-Ray measurement is possible according to customer requirements.

The geometry scanning of the lumber cross section is done with 800 scans per second and a width resolution of + / -1 mm. The scanning principle is largely insensitive against common lumber discoloring.

Optionally, the scanning system can be fitted with additional units and sensors for an automatic grade detection system.

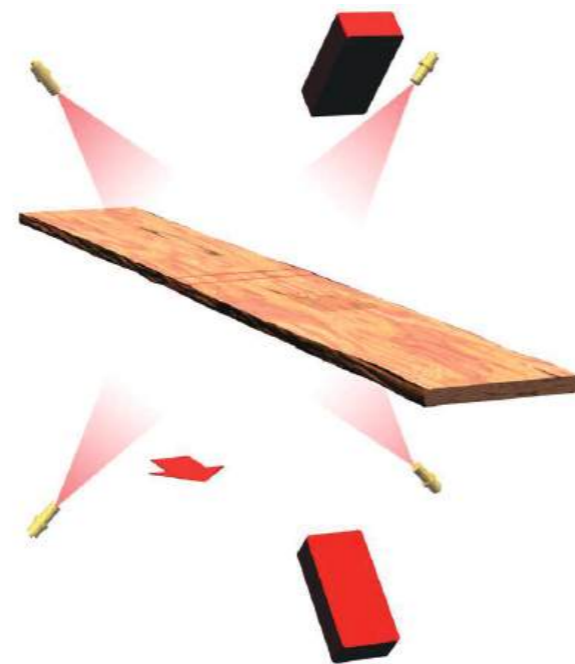
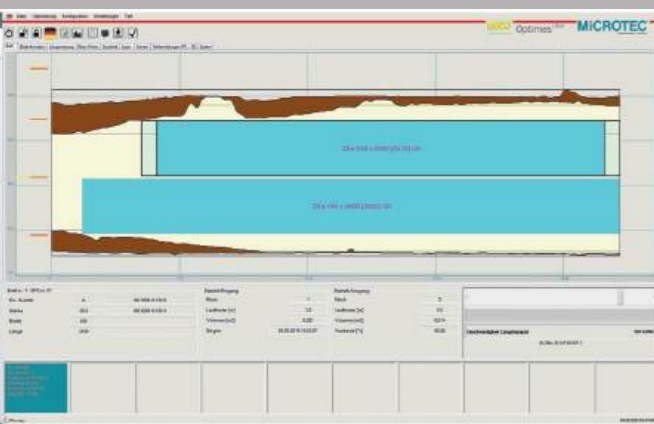
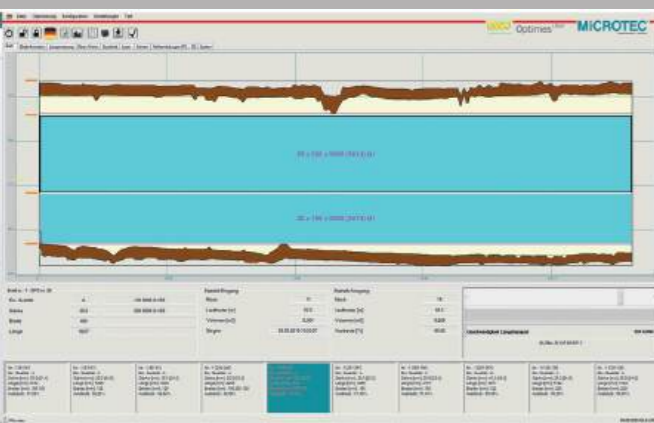

#### THE OPTIMIZATION SYSTEM

The PC processes the scan signals and compares top and bottom board face. The parameters for the value optimization can be easily adapted by either the operator or the mill management to match the actual production needs. Input of product parameters and priorities is done conveniently via the Windows operator interface of the PC.

In certain machine configurations, the optimization considers not only saw settings in the board as it was scanned, but also a skewing solution. Then a motion controlled system moves the saws sideways while cutting. No other edger system will match the precision of this closed-loop principle.

#### THE CONTROL SYSTEM

A high-performance industrial-standard PC processes the scan data and optimizes the edging and separation solutions. The PC with Windows operating system is at the same time a comfortable interface for all operator inputs and responsible for scanning, optimization and the complete data management.

The position values of the tools calculated by the optimization are transferred to a decentralised PLC. The PLC controls the sequence functions and hydraulic positioning, as well as the safety technology according to current requirements by using a safety PLC.

This guarantees a clean separation of data processing and machine control.

The system states are displayed graphically.

#### THE INPUT PARAMETERS FOR EDGING OPTIMIZATION

- Input of lumber species and grade
- Input of product dimensions with respective product value
- Input of allowed wane, by width, height and length, separate values for left and right side, for each product quality
- Input of product priority
- Automatic detection of 4-sided (finished) products

All parameters can be changed or updated while the system is operating.

The PLC control manages all machine parameters and controls the complete process of the system. The feed speed is automatically adjusted according to the board thickness and the number of saws cutting.

For summer and winter operation, different speeds can be specified.

An integrated diagnostics software with VPN access enables quick assistance for service calls and troubleshooting.

#### THE OPERATION

Depending on the requirements and capacity, the control of the system is done on the machine (partially automated system) or from a control cabin (automated system). An ergonomic, comfortable operator chair is an integral part of these systems.

# HIGH PERFORMANCE EDGER OPTIMIZER TECHNOLOGY

## OPTIMES

# OPTIMES

## Technical data



→ For high capacities and maximum value yield

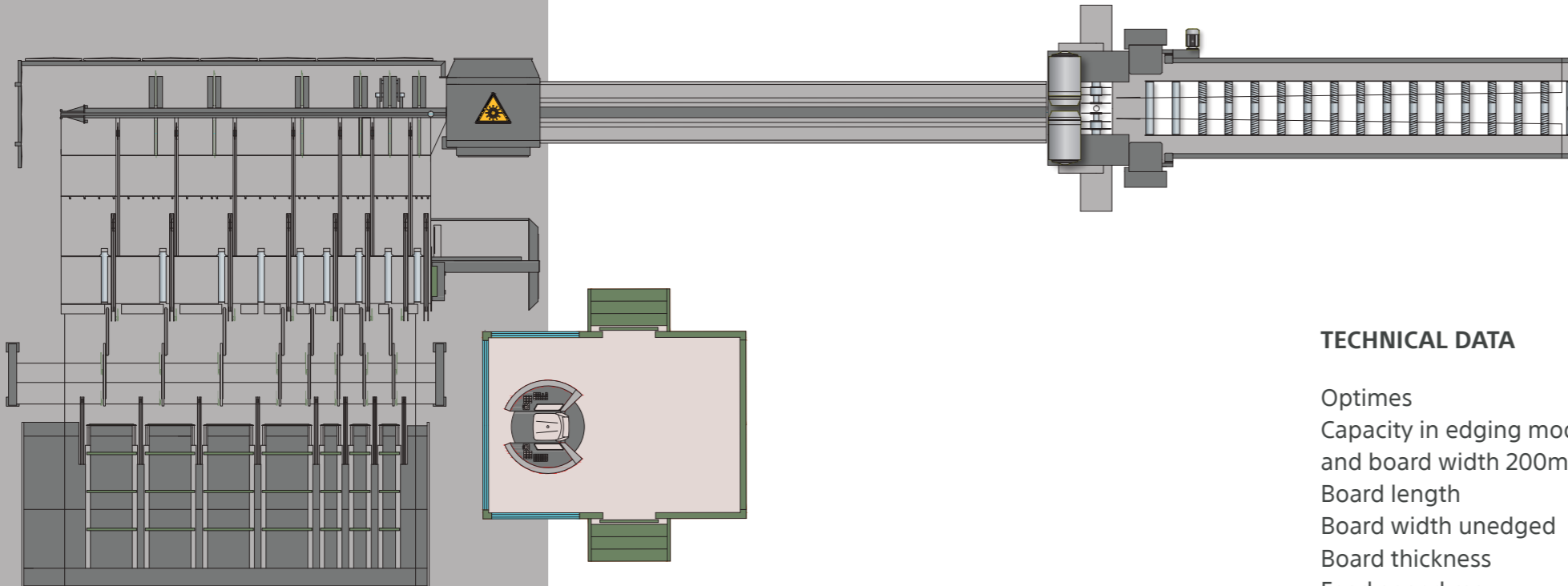

### TECHNICAL DATA

Optimes	BNK	BKO	BKO	BKO
Capacity in edging mode at board length 4.1 m and board width 200mm	30	30	38	42
Board length	1.2-6.0	1.2-6.0	2.0-6.0	2.0-6.0
Board width unedged	70-750	70-750	90-650	90-500
Board thickness	17-225	17-120	17-60 (100)	17-60
Feed speed max.	20-240	20-240	50-320	80-360
Partially automated	operation on the machine			operation from a cabin
Automated				

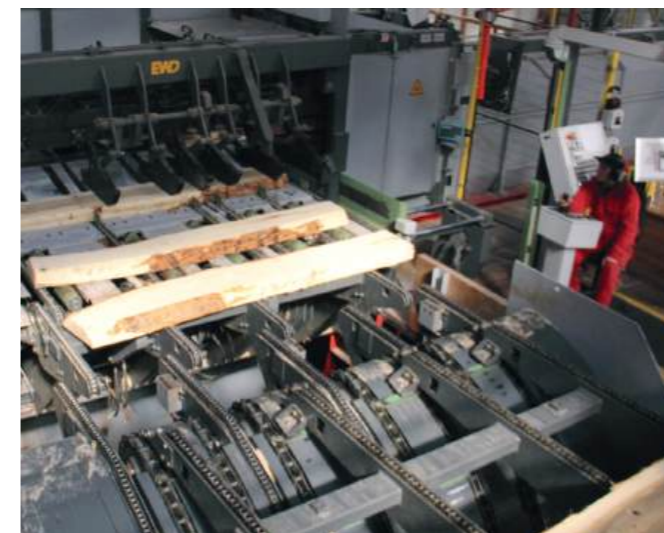

### → Maximum recovery

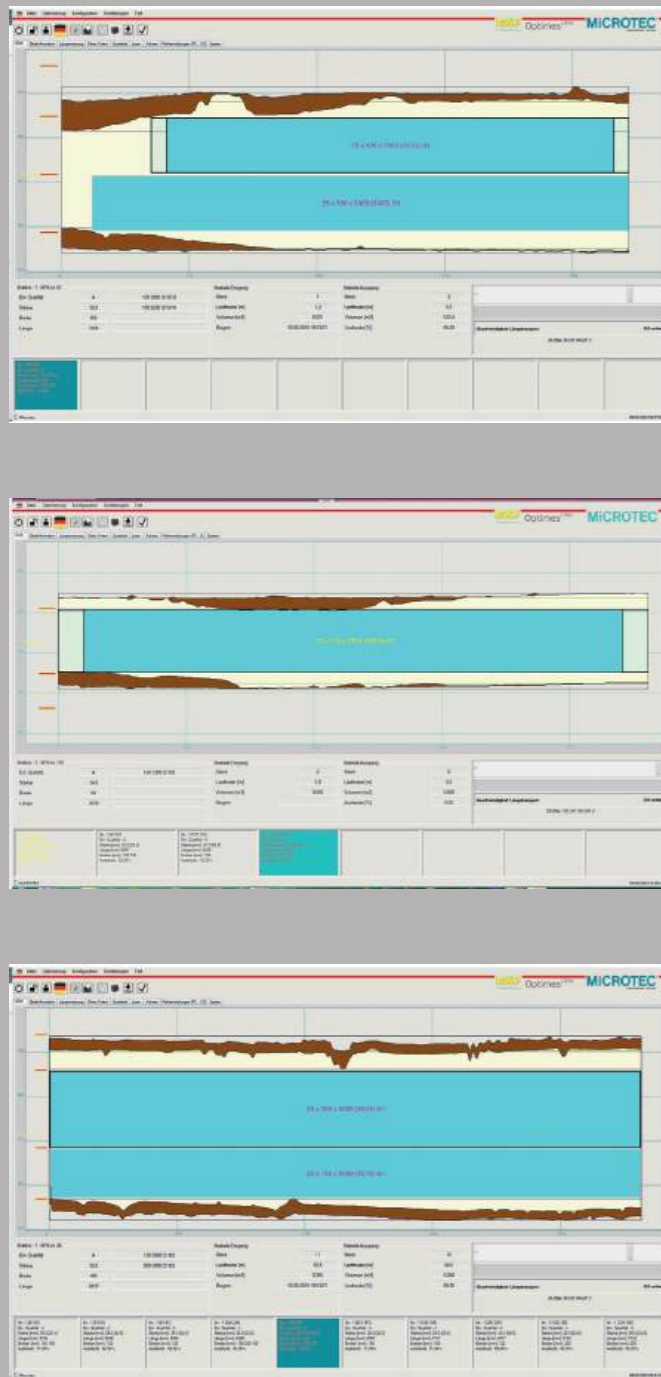

### THE BOARD MEASUREMENT

The board profile is scanned in linear or transverse transport by an optical measuring system. Both sides of a board are automatically scanned and the length and position of the wane is analysed. A wane allowance can be entered as percent or absolute value, separately for the left and right side.

Option: top and bottom mounted quality scanner

### THE CONTROL SYSTEM

A high-performance industrial PC with Pentium high-performance processor is used for the processing of scan data and optimization. The PC with Windows operating system provides a comfortable system for operator input and carries out the entire data processing.

The position values of the tools calculated by the optimization are transferred to a decentralised PLC, the sequence functions and hydraulic positioning, as well as the safety technology according to current requirements by using a safety PLC.

This guarantees a clear separation of data processing and machine control.

The system states are displayed graphically.

### THE OPERATION

The operation of the entire system takes place in a control cabin. The ergonomic, comfortable operator chair is an integral part of the system.

### THE FUNCTIONALITY

The supplied boards are singulated in an S-shaped chain transverse transport. Adjustable ejector cams automatically kick out the leading board when it is double-occupied so that it slips off.

Sensors for monitoring and automatic control of the unscrambler guarantee high availability and effectiveness.

After unscrambling, a cascade system with toothed chains and patented EWD stop hooks follows.

For troubleshooting, the feeding conveyors can reverse and transport products back to the unscrambler.

For transverse-scanning systems, board scanners of different designs can be implemented in this area. Their data can then be entered into optimization systems with customer-specific targets.

The OptiDrive infeed table uses driven positioning heads and pressure rollers to achieve previously unattainable high-availability acceleration values.

### THE MAIN FUNCTIONS OF EDGING OPTIMIZATION

- Choice of lumber species and quality
- Input qualities
- Thicknesses with qualities

Input of allowed wane per quality possible.

The optimization determines the best edging solution, by volume or value, using the stored product dimensions, qualities and prices, and optionally by product priorities.

All parameters can be modified while the machine is operating.

The feed speed of the system is set automatically at maximum according to the load or can be limited if desired.

An integrated diagnostic software with VPN access enables quick assistance for service calls and troubleshooting.

### THE TECHNICAL COMPONENTS

Unscrambler:

Adjustable ejector cams, sensors and automatic control of the unscrambler cross conveyors for high efficiency

### THE GRADING AND BOARD HANDLING STATION

Sharp chains, stop hooks, board turner with the flow, 0-saw and driven feed rollers for trimming of fishtail slabs

Transverse scanning conveyor:

Sharp chains, stop hooks, scanner system

Infeed system:

- Sharp chains in cross transport for loading of boards
- 4-5 pairs of driven or idle positioning heads
- 4-5 pressure rollers and 4-5 lifting board supports
- Sharp chain as infeed chain to the edger

# HIGH PERFORMANCE EDGER OPTIMIZER TECHNOLOGY

## OPTIDRIVE | BKO

# OPTIDRIVE | BKO

## Technical data



→ Transverse scanning system

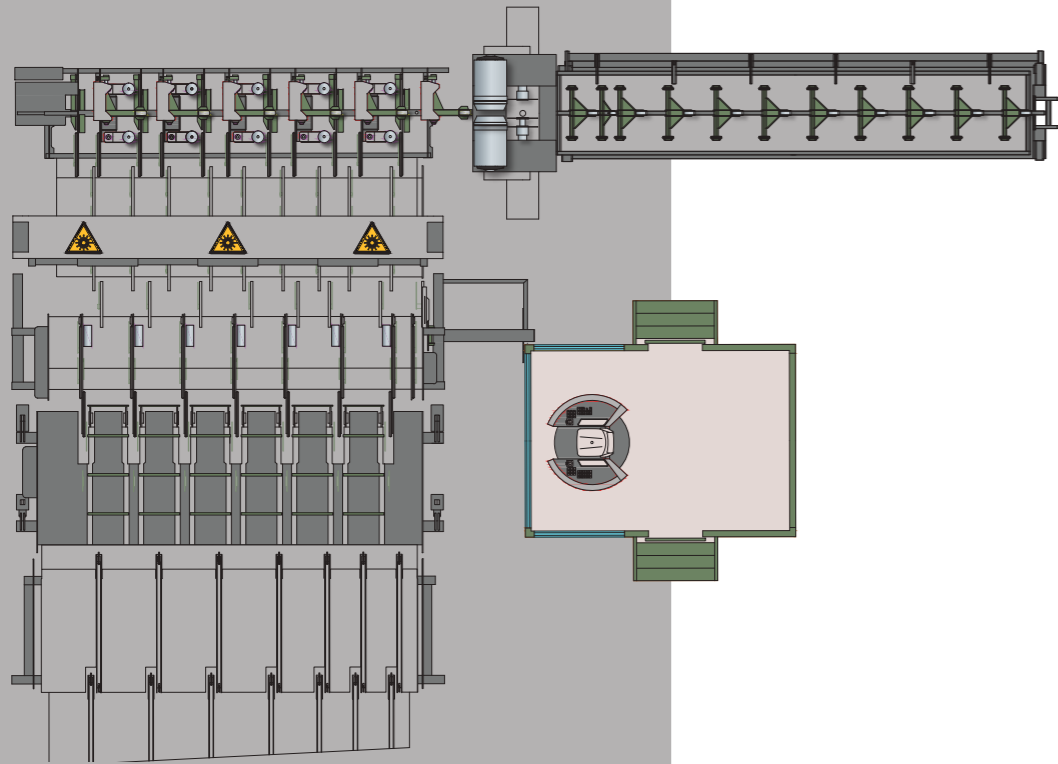

→ Linear scanning system

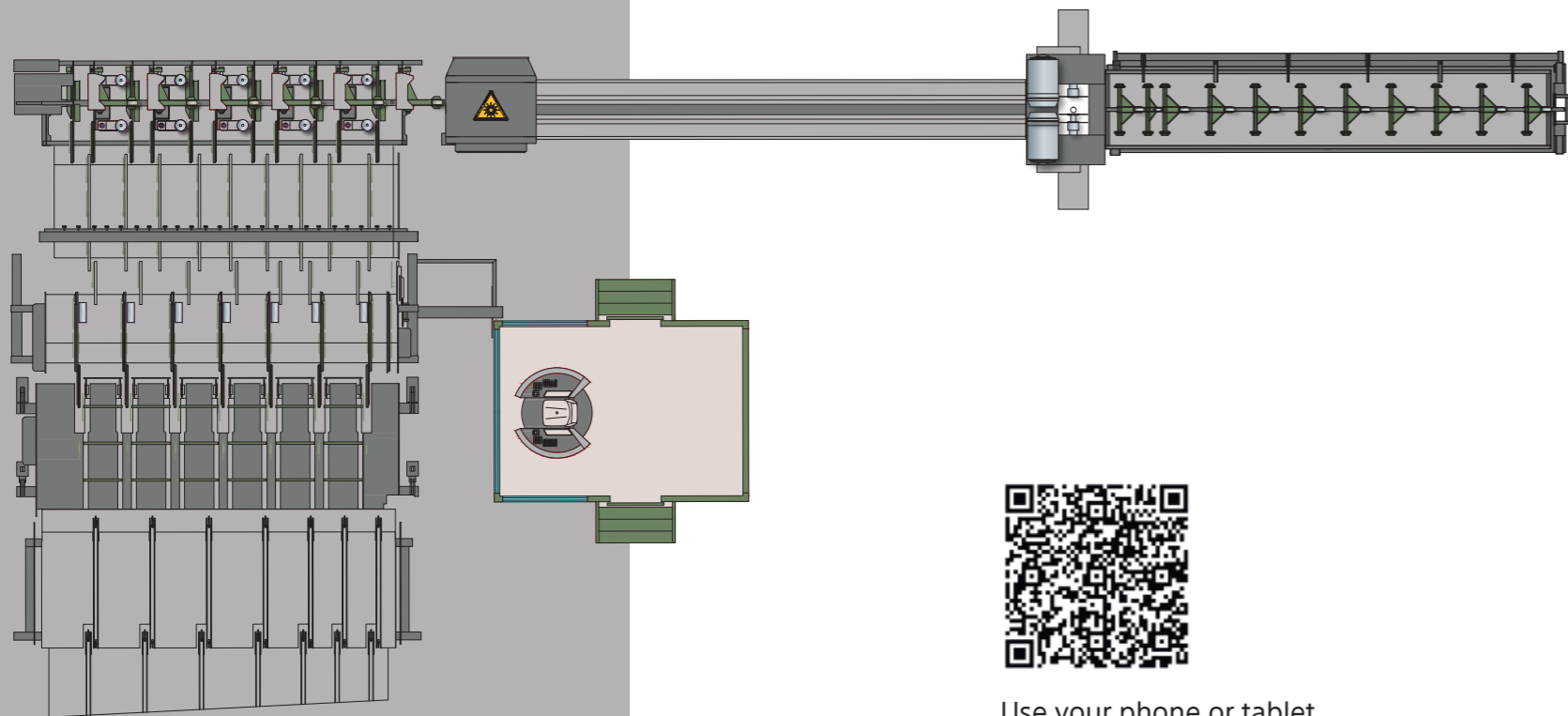

Use your phone or tablet to scan this QR Code and see the Optidrive in action.

### TECHNICAL DATA

Capacity in edging mode at board length 4.1 m and board width 200mm max. piece/min 60

Capacity in edging mode, slew at board length 4.1 m and board width 200mm max. piece/min 57

Board length	m	2.4-6.0
Board width unedged	mm	90-550
Board thickness	mm	17-55
Automated		operation from a cabin

### TECHNICAL DATA BKO

Feed speed max.	m/min	420
Saw arbors drive	kW	2 x 75-132
Weight including drive motors approx.	t	5.8

### SAW SET DISTANCE BKO3

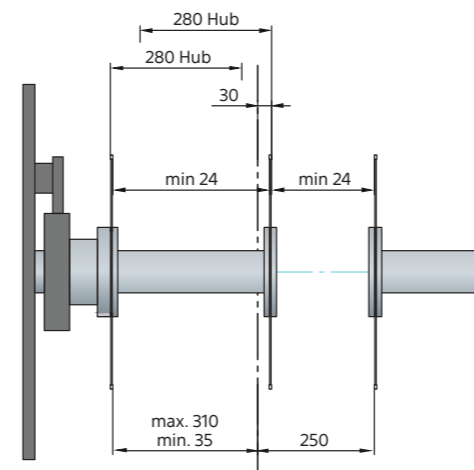

TAE - a pivoting edger machine with saw shifting up to 25mm/m for all possible lumber thicknesses, used for challenging board shapes or in combination with a longitudinal grade scanner.

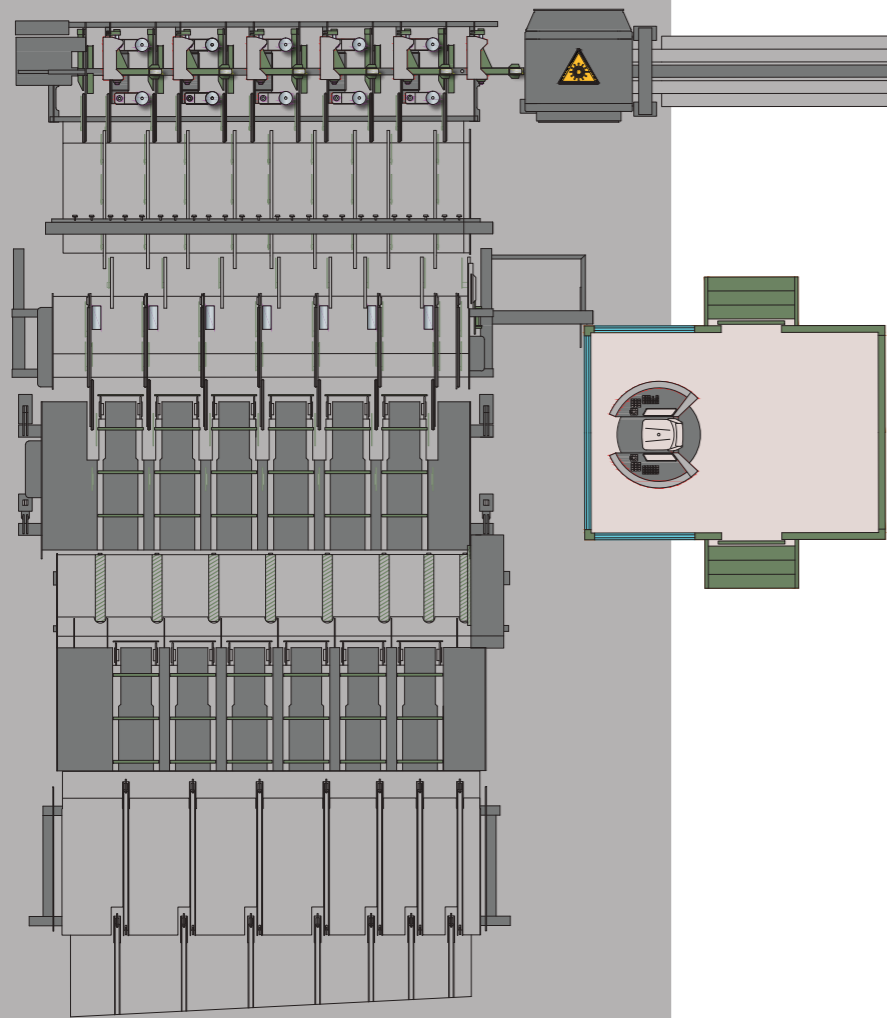

Use your phone or tablet to scan this QR Code and see the Optidrive in action.

**TECHNICAL DATA**

Capacity in edging mode, skew and slew at board length 4.1 m and board width 200mm max.  
piece/min 57

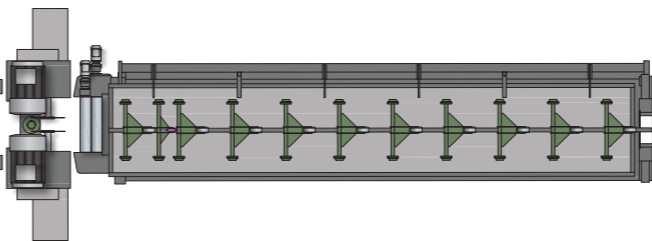

Board length	m	2.4-6.0
Board width unedged	mm	90-550
Board thickness	mm	17-55
Automated	operation from a cabin	

**TECHNICAL DATA TAE PIVOTABLE**

Feed speed max.	m/min	420
Saw arbors drive	kW	2 x55-110
Weight including drive motors approx.	t	5.4

**SAW SET DISTANCES TAE 2**

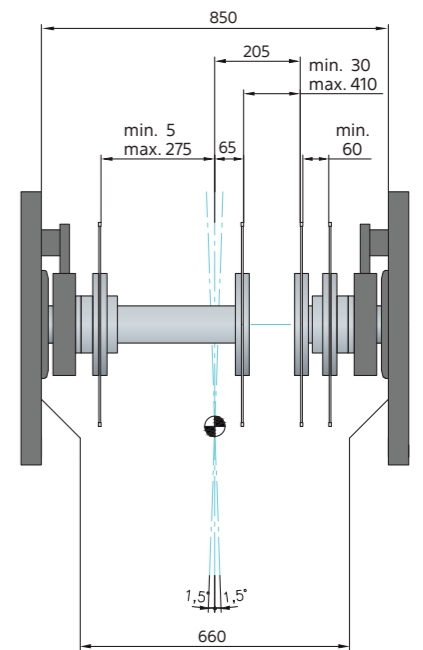
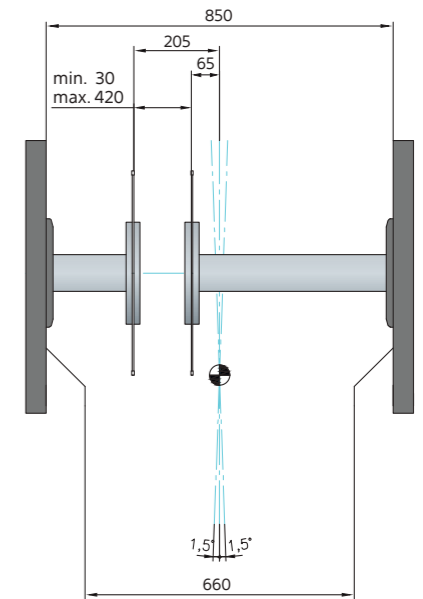

# HIGH PERFORMANCE EDGER OPTIMIZER TECHNOLOGY

## OPTIDRIVE | Remote-controlled

# OPTIDRIVE | REMOTE-CONTROLLED

## Technical data



The system is designed for remote-controlled operation and is operated without a direct operator.

The field of application is for suitable applications without the need for board trimming prior to edging and usually diameter sorted sawing on the main machines.

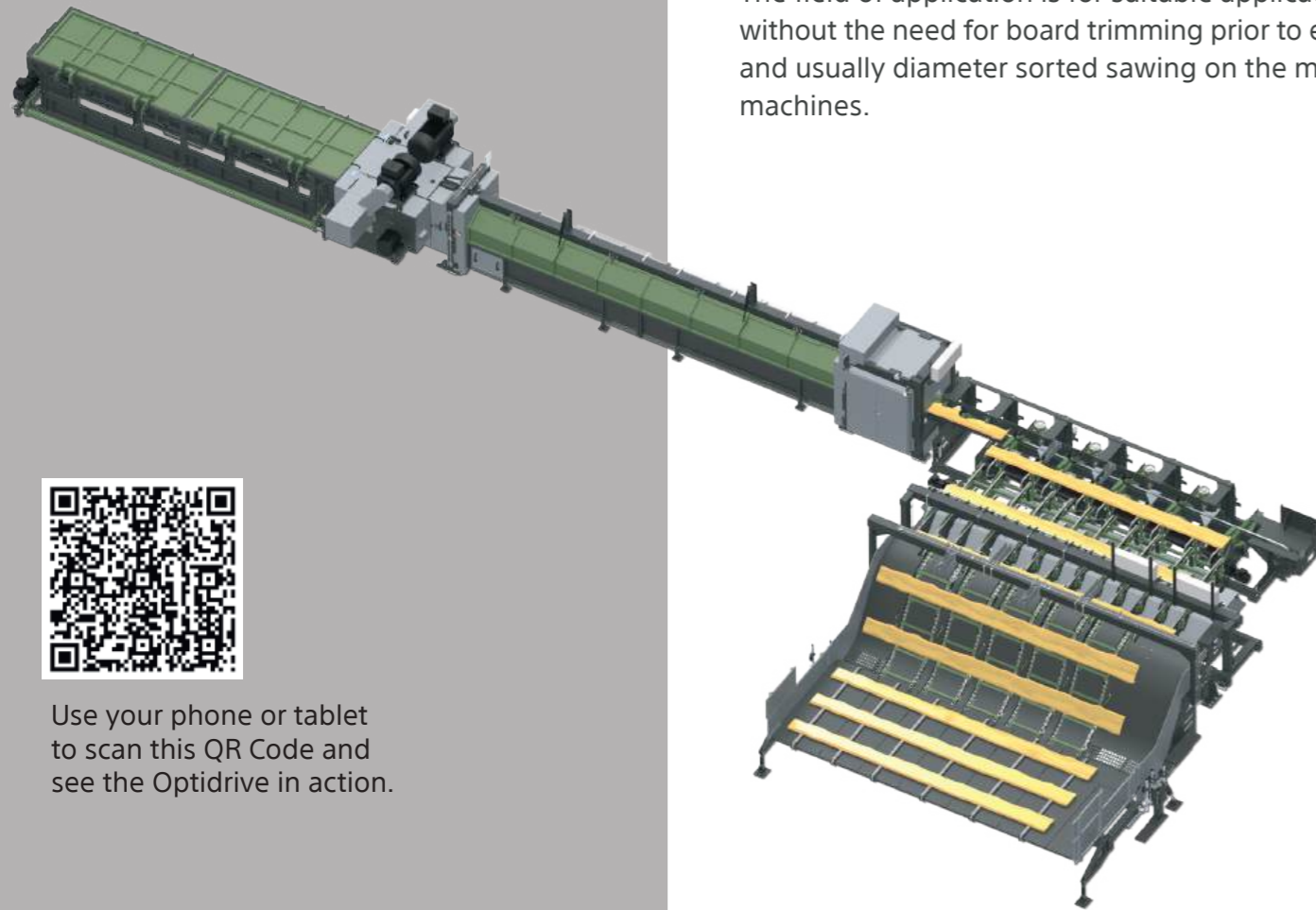

Use your phone or tablet to scan this QR Code and see the Optidrive in action.



### TECHNICAL DATA

Capacity in edging mode at board length 4.1 m and board width 200mm max. piece/min 55

Capacity in edging mode, slew at board length 4.1 m and board width 200mm max. piece/min 52

Capacity in edging mode, skew and slew at board length 4.1 m and board width 200mm max. piece/min 52

Board length	m	2.4-6.0
Board width unedged	mm	90-550
Board thickness	mm	17-55
Automated		remote controlled

### TECHNICAL DATA BKO

Feed speed max.	m/min	420
Saw arbors drive	kW	2 x 75-132
Weight with drive motors approx.	t	5.8

### TECHNICAL DATA TAE PIVOTABLE

Feed speed max.	m/min	420
Saw arbors drive	kW	2 x 55-110
Weight with drive motors approx.	t	5.4

### SAW SET DISTANCES TAE 2

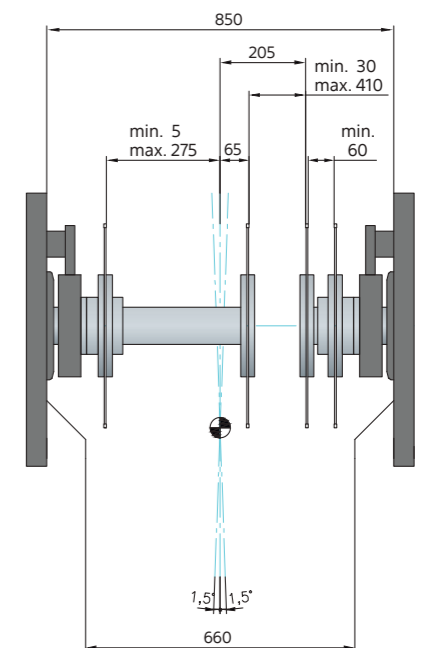
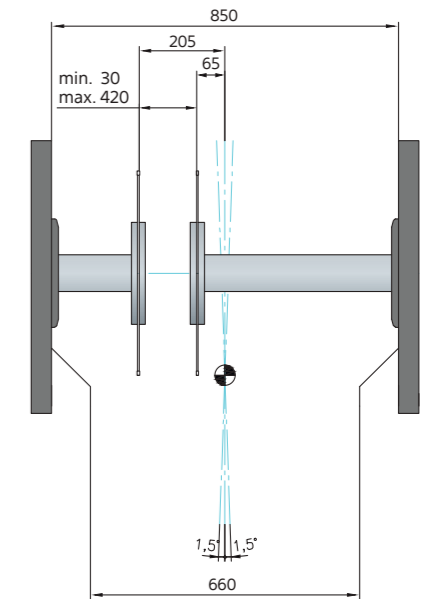

### SAW SET DISTANCES BKO3

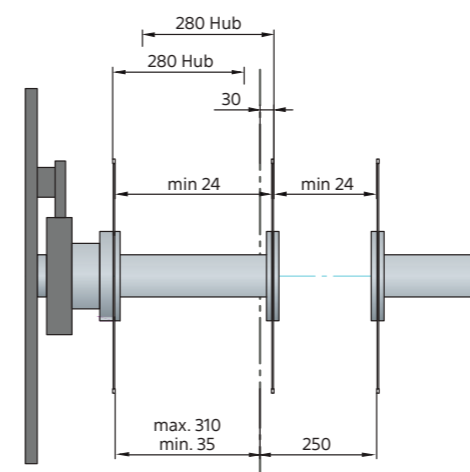



**EWD**

Esterer WD GmbH  
Estererstraße 12  
D - 84503 Altötting

T +49 8671 503 0  
F +49 8671 503 386

Markwiesenstraße 40  
D - 72770 Reutlingen

T +49 7121 5665 0  
F +49 7121 5665 400

[info@ewd.de](mailto:info@ewd.de)