



CIRCULAR SAW & PROFILING TECHNOLOGY

EWD

ZE 2 Align and infeed system

- Scan
- Optimise
- Rotate
- Align
- Chip

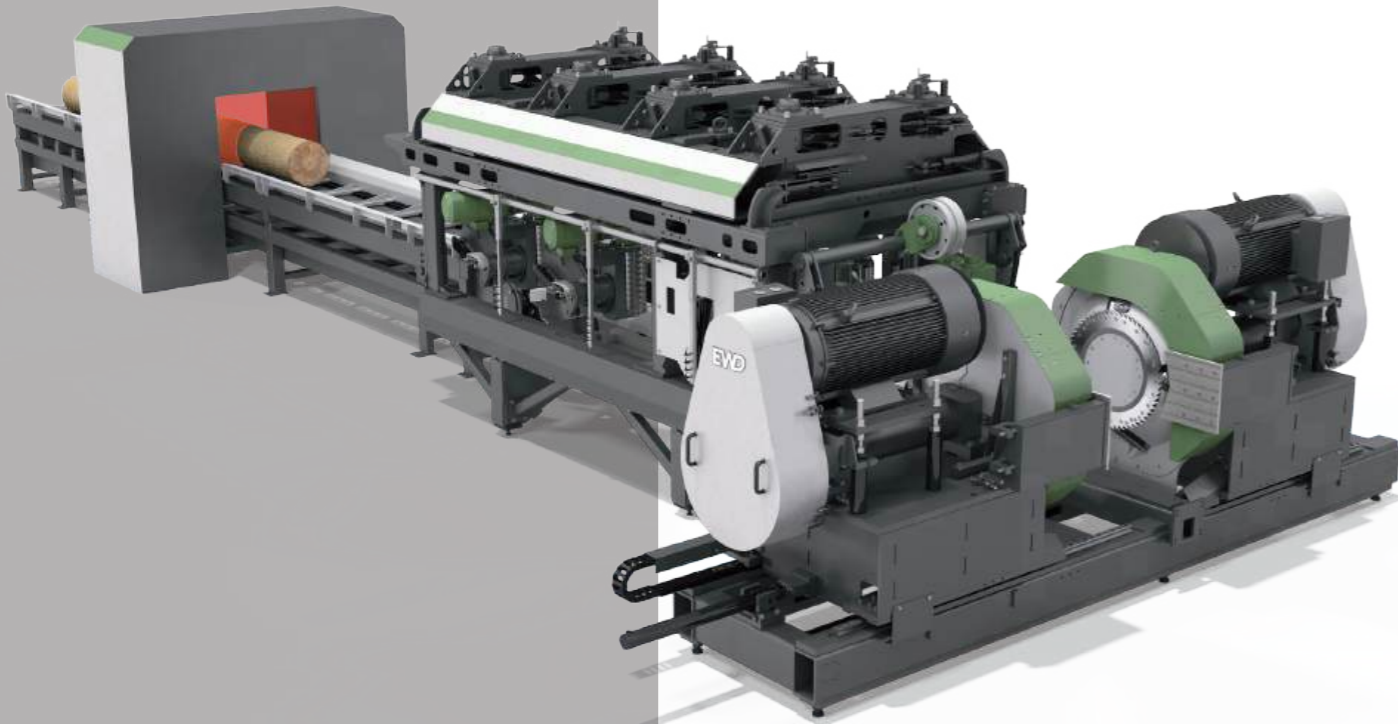

The completely new designed align and infeed system ZE 2 with top-mounted skewing frame and top activated roller pairs offers many advantages:

- The modular design allows the optimum adaption to the requirements of all kinds of log and two-sided cant infeed systems in modern industrial sawmills.
- Easy deflection of bark and broken lumber pieces as well as dirt and ice.
- Easy access for routine checks and maintenance works.
- Easy change of transport chains and rollers.
- Less cleaning required, in particular of moving components.

ZE 2 Align and position

Logs can be rotated very precisely in their required orientation, following a 3D true shape scanning and optimisation, at highest feed speeds and with minimum log gap.

The logs are positioned either to machine centre line, parallel side shift or diagonally to the machine centre line, depending on their shape and sweep.

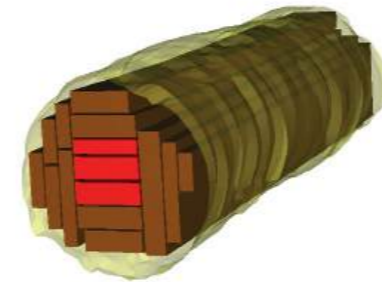

The cant alignment is done based on 3D scanning and sawing pattern optimisation, again parallel to the machine centre line or diagonally to the machine centre line. The ZE 2 allows increasing the recovery by sawing of logs and cants with asymmetric cutting patterns to get the most out of them.

Only two servo-hydraulic networks are required to perform optimised log and two-sided cant orientation with skew and shift in straight sawing mode.

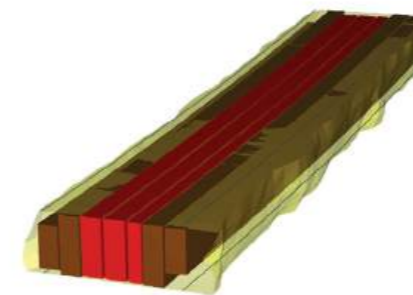

Curve sawing mode is made by means of a sliding frame with servo axis.

OPTIONS:

- FZ 1 chipper canter
- Small end position setting
- 4 - sided cant turning device



TECHNICAL DATA

Log/cant length	m	from 1.8
Minimum small end diameter	mm	100
Max. log diameter	mm	750
Cant height	mm	60–500
Max. opening of rollers	mm	780
Feed speed	m/min	up to 200
Max. side shifting/skew	mm	+ / - 90
Sweep for active curve chipping	mm/m	10
Weight of standard infeed table and log length max. 6m	t	16

PF 19
Universal chipper canter



→ For medium to large Reducing and Profiling lines.

The chipper canter PF 19 is used in Circular saw or Reducer Bandsaw lines and also in Profiling lines for chipping of two parallel faces on logs or cants. The width adjustment of the chipper head supports is done by servo-hydraulic networks.

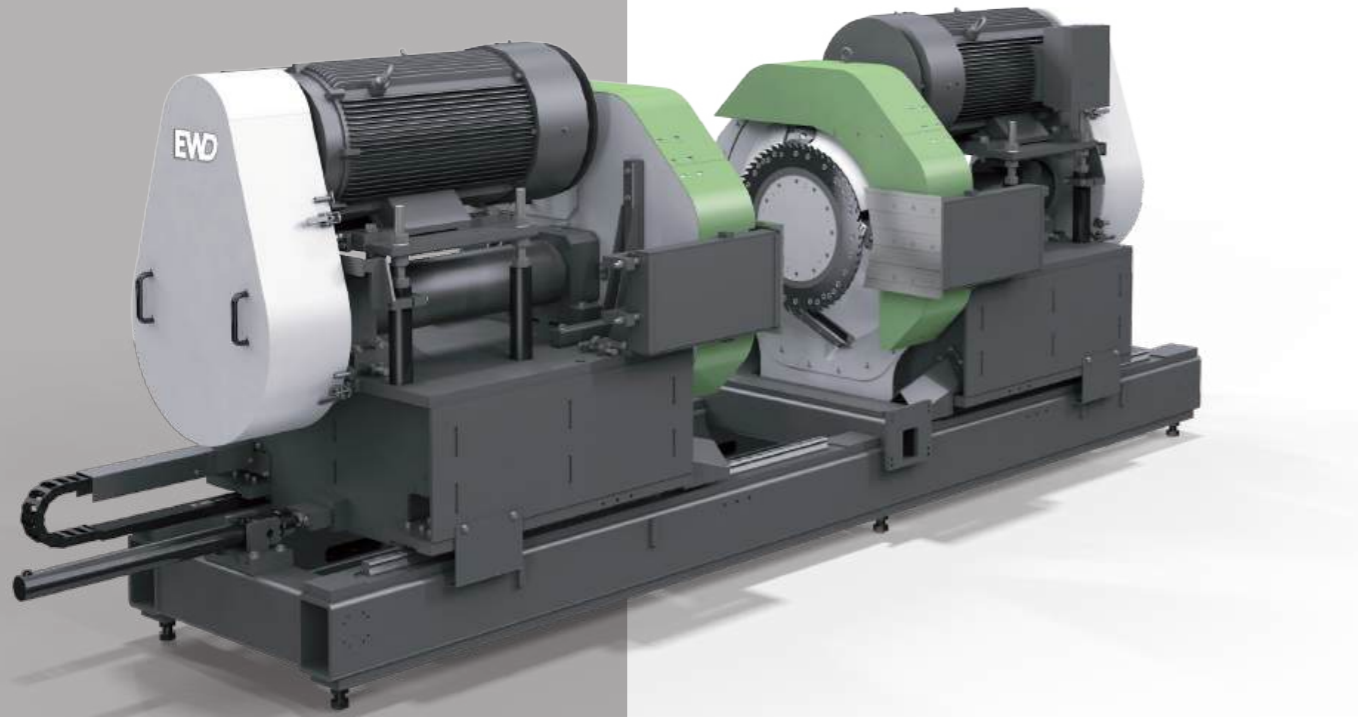

The produced chips meet the high quality requirements of the pulp industry.

The chipper head revolutions are controlled by a frequency converter as a function of feed speed and desired chip lengths.

Sliding platform for easy and safe access for tool change and maintenance.

CHIPPER HEAD
Straight knives / Spiral knives

The chipper canter PF 19 can be fitted with either straight knives, spiral knives or stepped knives heads.

The different head types are matched by the number of tools installed to the desired speed range.

All heads are fitted with either pre- or post-sawing circular saw rings, depending on the purpose.

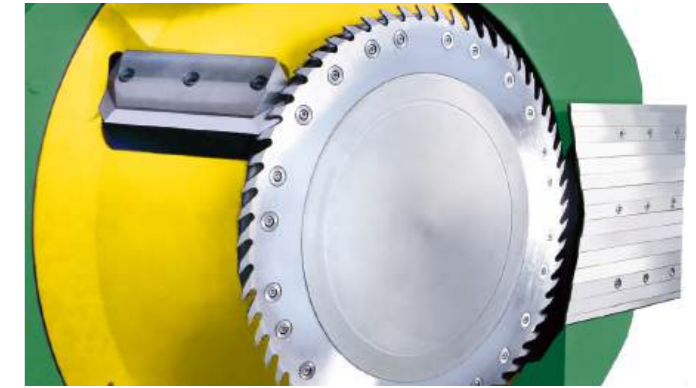

TECHNICAL DATA PF 19

Chipper head diameter		
Straight knives chipper head	mm	1240
Spiral knives chipper head	mm	1260
No. of main knives (straight knives head)	pcs.	3, 4, 6
No. of spirals (spiral knives head)	pcs.	3, 4, 5
Chipping depth per head max.		
Straight knives chipper head	mm	190
Spiral knives chipper head	mm	180
Chipping height above chain bed max.		
Straight knives chipper head, pre-sawing	mm	612
Straight knives chipper head, post-sawing	mm	505
Spiral knives chipper head, pre-sawing	mm	580
Spiral knives chipper head, post-sawing	mm	540
Distance between the chipper heads in operation	mm	60-700
Opening side for tool change	mm	900
Feed speed	m/min.	20-150
Drive power	kW	2x75- 2x250 (at 1500 1/min)
Machine weight with drive motors (2x250kW)	t	13.0



eWood is a comprehensive optimisation and application software from EWD. All modern EWD sawlines and machines share the same eWood user interface.

The interface man – machine offers an intuitive and consistent user concept, allowing effective use of the functions after just a short training period.

- Most modern measuring technology
- Professional optimisation and application software

In addition to solid and time-proven mechanical engineering, efficient system controls are essential prerequisites for the high efficiency and yield of the EWD sawlines

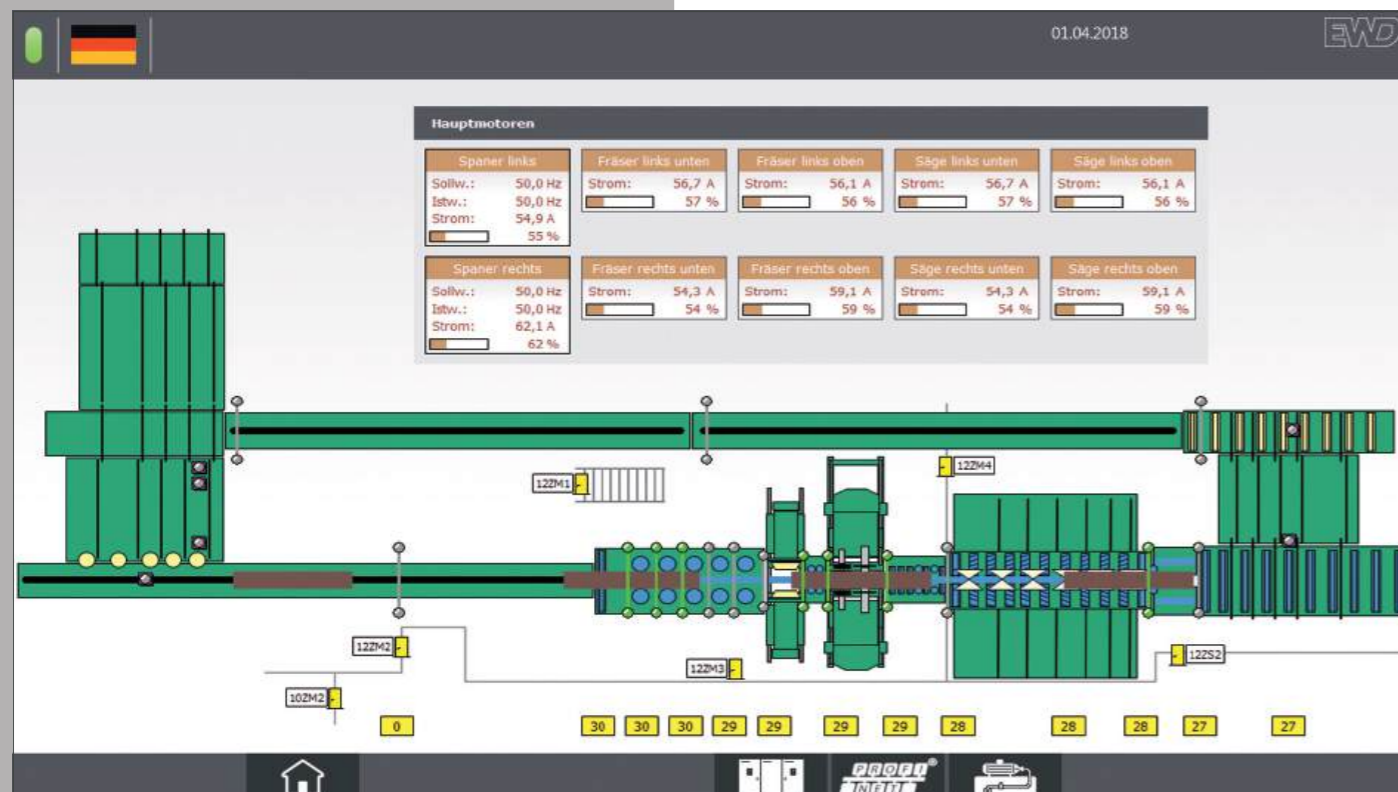

Statistics | Evaluation



Maintenance plan

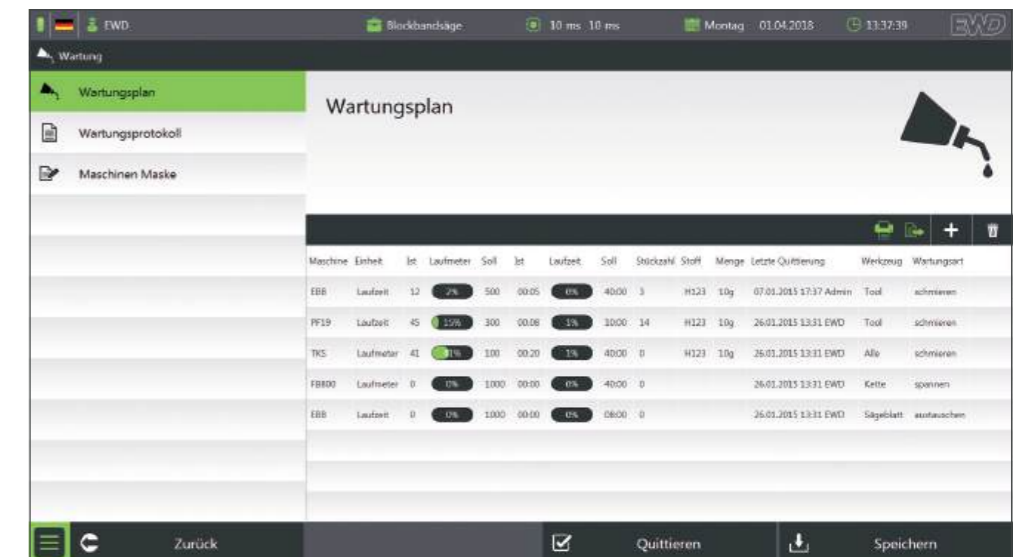

Product listing, 4-sided cants

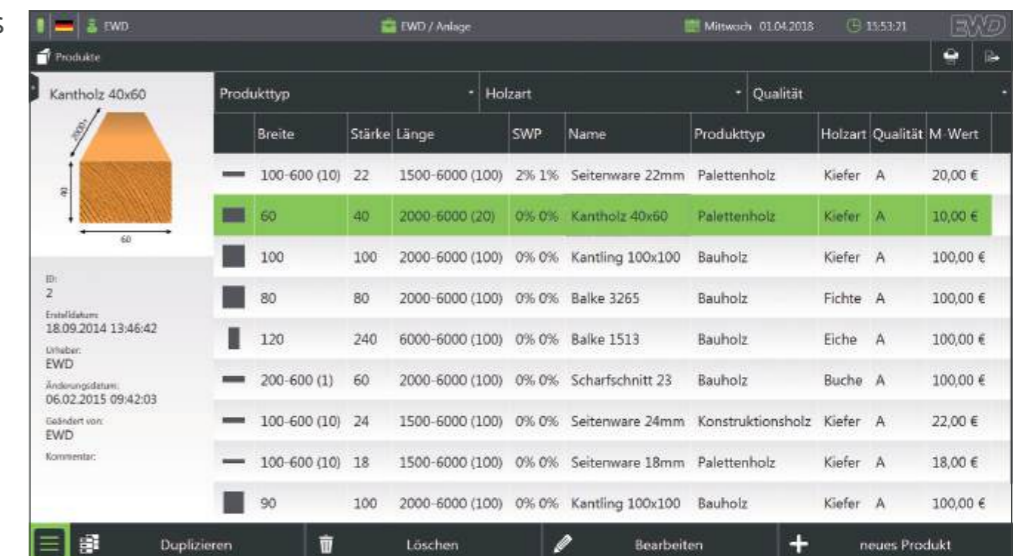

LOG AND CANT CIRCULAR RESAW DWK



→ Flexible double arbor circular saw for primary and secondary breakdown with excess height cutters and hydraulically height-adjustable saw arbors.

The flexible double arbor circular saw unit DWK 700 is used as primary-, secondary break down or combination machine in medium to large sawmills. In total 6 pairs of saw heads can be positioned individually with very precise servo-hydraulic networks.

For a uniform distribution of the actual sawing heights on top and bottom saw blades, the saw arbors are automatically positioned in height. For use as a primary break down machine, the DWK 700 is fitted with excess height cutters, which are adjusted in height together with the saw arbors. This tool arrangement enables a very efficient sawing operation of even large diameter logs.

Sliding platform for easy and safe access for tool change and maintenance.



Use your phone or tablet to scan this QR Code and see the DWK in action.

TECHNICAL DATA DWK 700

Log diameter (described in a tube) max	mm	700 (800)
Log length min.	m	2.5
Sawing height primary breakdown with excess height cutters	mm	380
Sawing height secondary break down	mm	48-370
Saw arbor length fix	mm	208
mounted saws per side	mm	205
Saw arbor diameter	mm	800
Machine opening outfeed unit max.	mm	643
Saw blade diameter top and bottom	m/min	100
Feed speed max.	kW	4x110 - 4x250 (at 1500 1/min)
drive motors	t	25
Machine weight with drive motors	mm	308
Excess height cutters	mm	160
Head diameter	mm	160
Head width	kW	4x45 (at 3000 1/min)
Drive motors		

SAW SETTING DISTANCES (in mm)

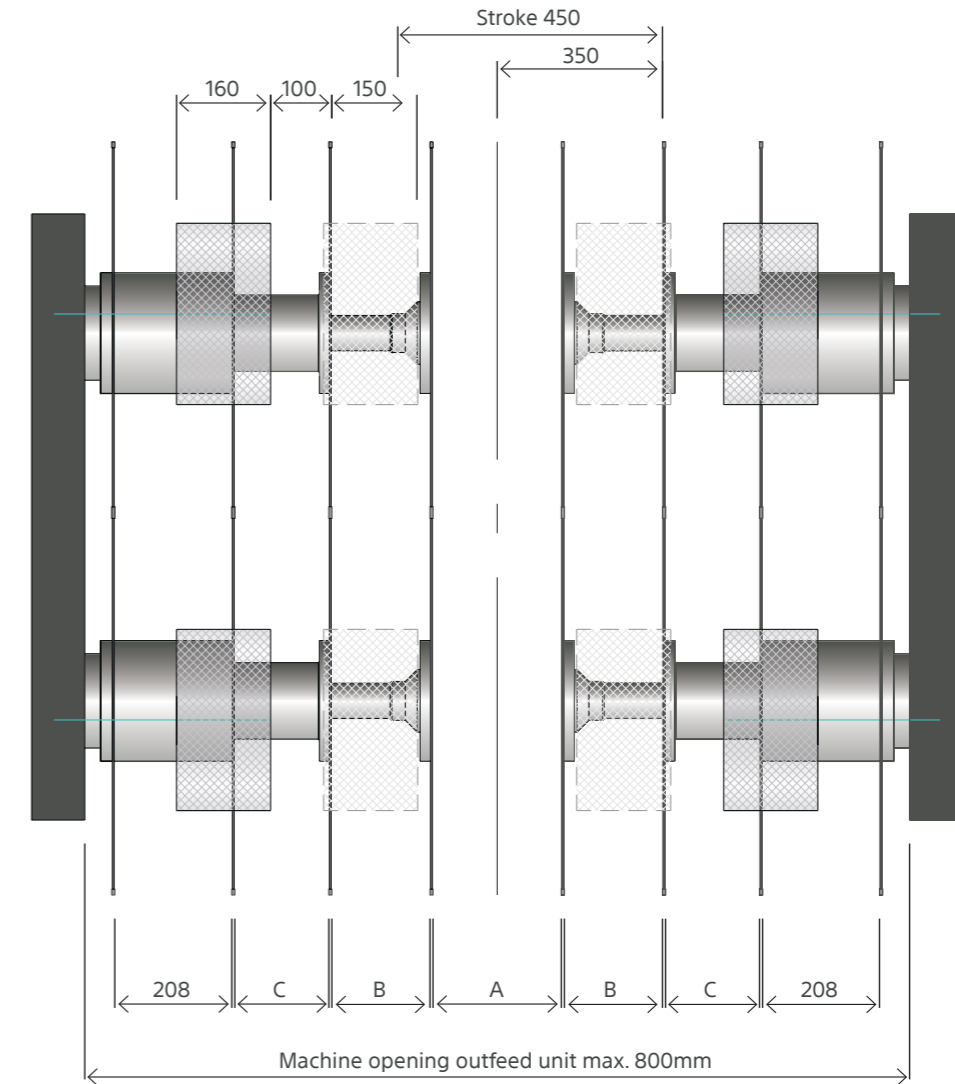

A = 18-650mm C = 18-168mm
B = 18-208mm A max. = 1600mm in tool change position

APPLICATION EXAMPLES DWK 700

Primary break down

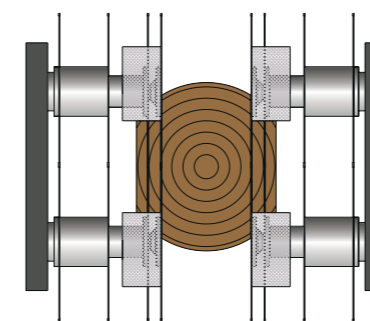

Secondary break down

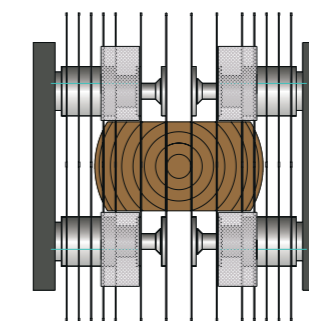

Cant and profile sawing

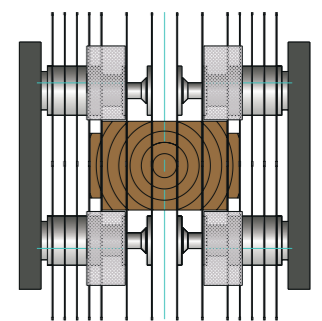

→ Flexible double arbor circular saw DWK with excess height cutters



The DWK log and cant circular resaws are characterised by a wide range of applications and enormous flexibility, substituting frame saws.

ADVANTAGES COMPARED TO A TRADITIONAL FRAME SAW OPERATION

- More center product yield, less side boards
- High sawing accuracy
- Super circular sawn lumber finish
- No vibrations
- Small foot print and less mechanization around required
- Relieves the operator at the edger optimizer
- Increases the throughput at the „bottleneck machine“ edger optimizer considerably
- Increased overall availability of the sawmill by chipping all slabs on the log or cant
- Optimum integration of the operator in the process flow

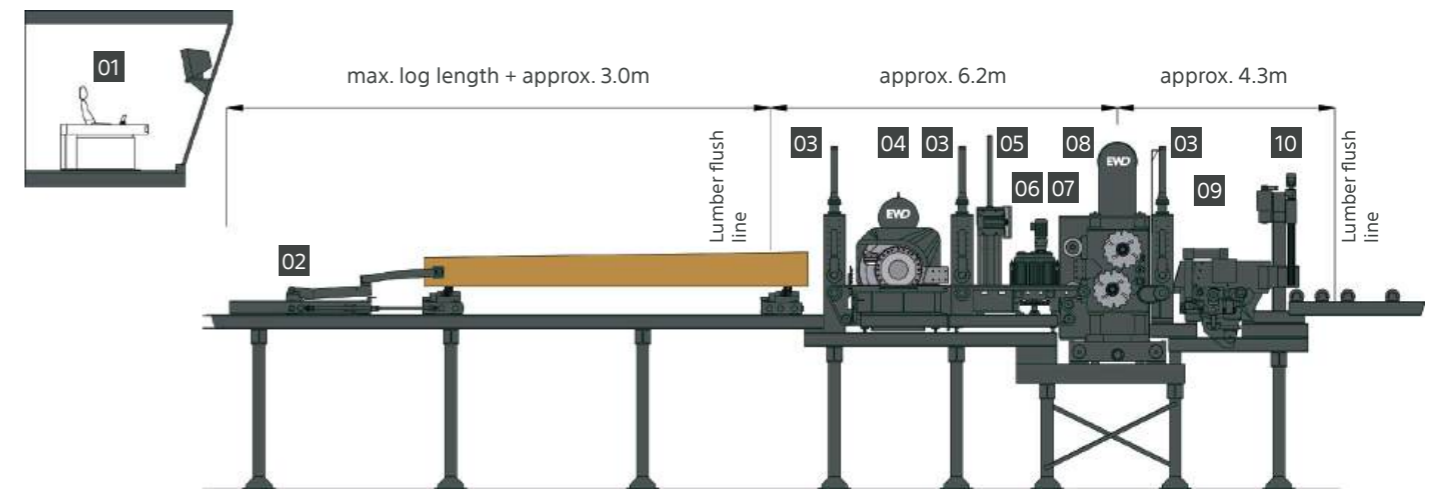
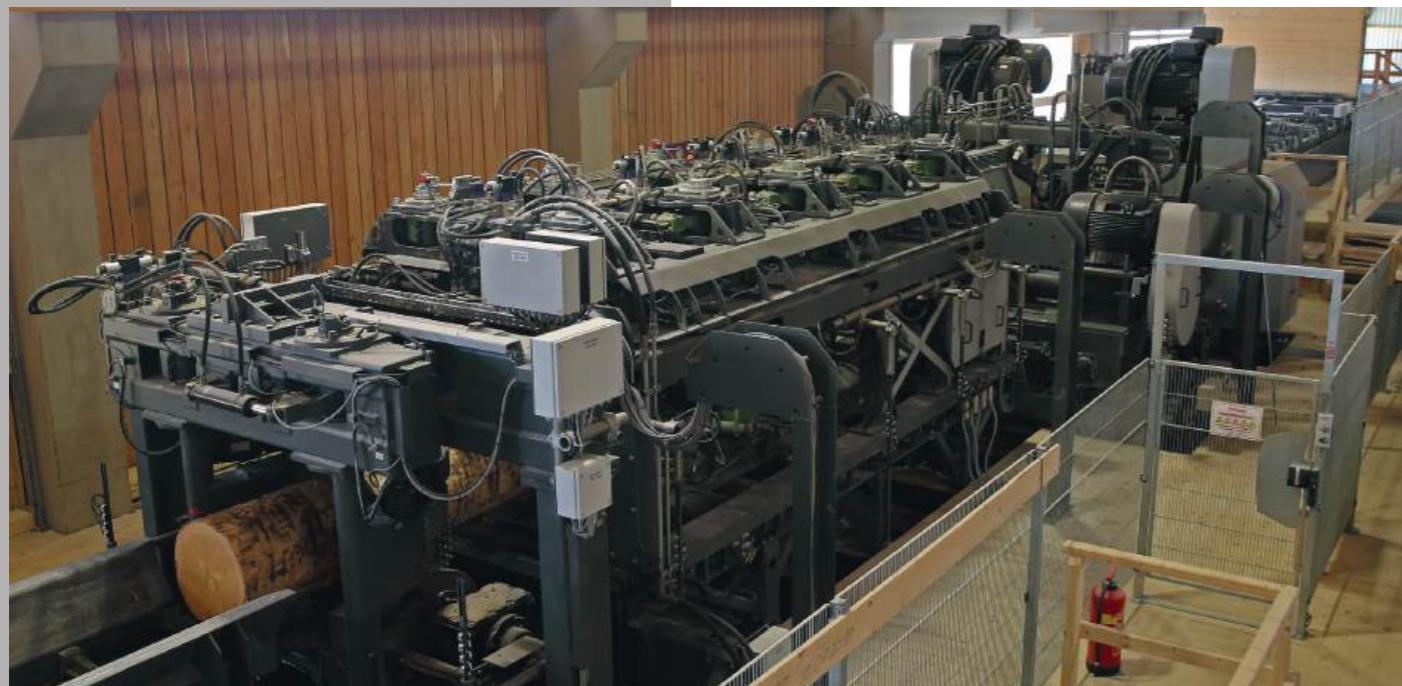

- 01 Modern operator control place, individual design available
- 02 Infeed system with independently adjustable log bunk and auxiliary carriage – H38/DWK
- 03 Horizontal driven feed roller system – WA1
- 04 Chipper canter – PF19
- 05 Automatic side board trim saw – KSB
- 06 Vertical feed roller system – EVW/K
- 07 Excess height cutters, adjustable in height with the saw arbors

- 08 DWK double arbor machine
 - fix distance between the saw arbors
 - with six independently moveable saw heads
 - independently moveable lumber guides for the re-sawing of four-sided cants
 - saws and lumber guides set by servo-hydraulic networks
- 09 Splitting plates – AVER/DWK
- 10 Additional outfeed rollers – AZV-1

SAW ARBOR HEIGHT ADJUSTMENT SET DISTANCES

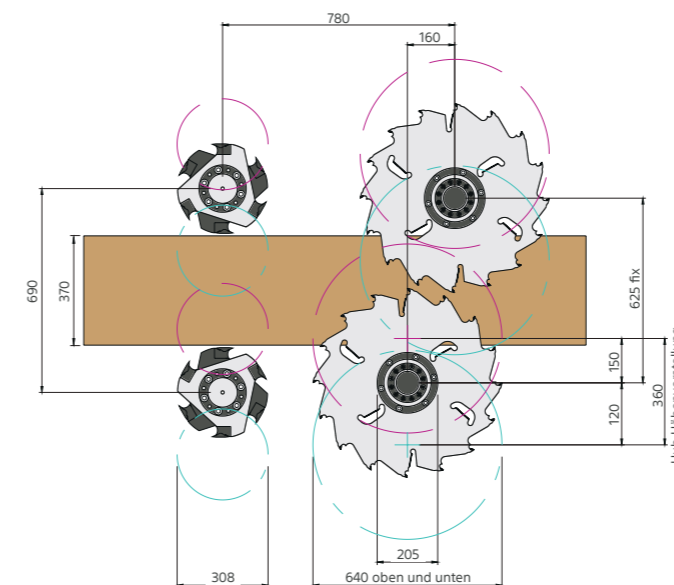

LOG AND CANT CIRCULAR RESAW VNK



→ Flexible double arbor circular saw
VNK without excess height cutters

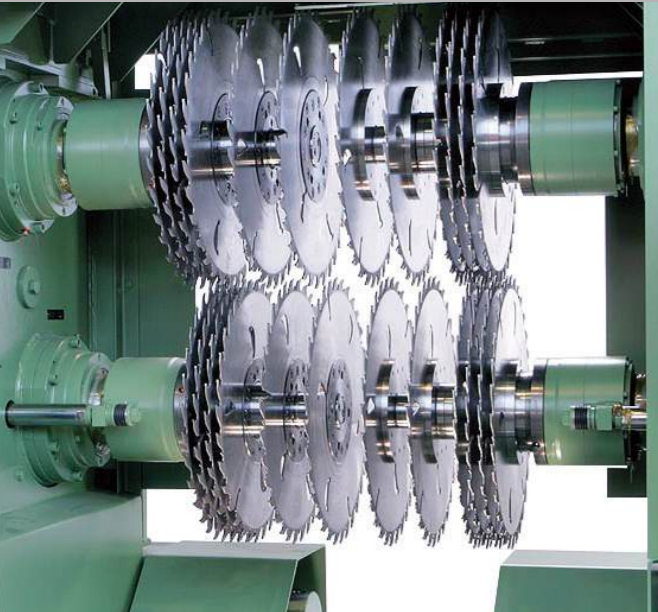

The flexible double arbor circular saw unit VNK is used as primary-, secondary break down or a combination machine in medium to large sawmills. In total 6 pairs of saw heads can be positioned individually with very precise servo-hydraulic networks.

For a uniform distribution of the actual sawing heights on top and bottom saw blades, the saw arbors are automatically positioned in height. All blade flanges are equipped as changeable flanges for quick saw change.

Sliding platform for easy and safe access for tool change and maintenance.

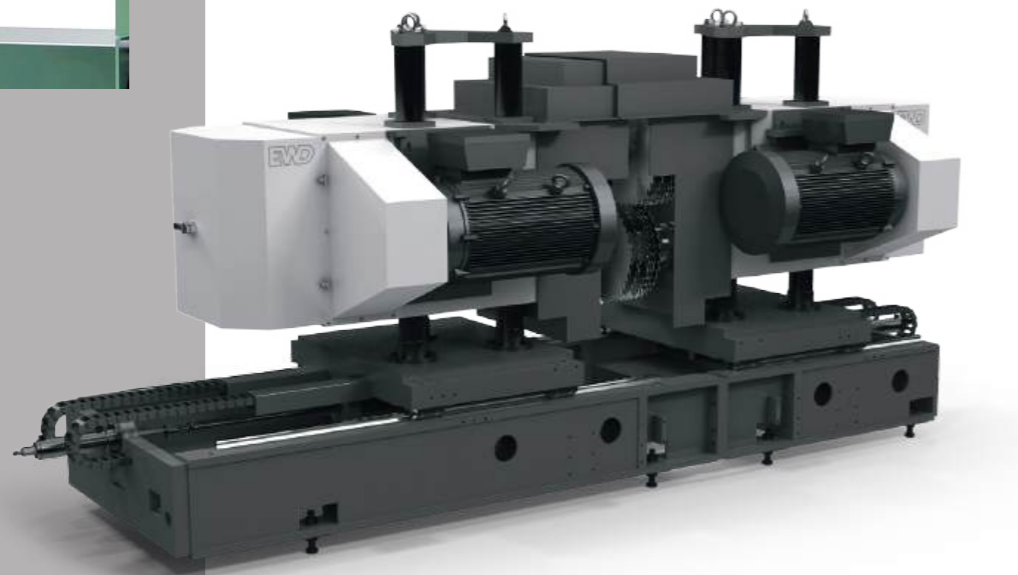

TECHNICAL DATA VNK 300 / VNK 360

Sawing height	mm	75-310 (VNK 360 75-360)
Log/cant length min.	m	2.4
Saw arbor length fix	mm	115
mounted saws per side	mm	240
Saw arbor diameter	mm	700
Machine opening outfeed unit max.	mm	610 (*655)
Saw blade diameter top and bottom	mm/min	140
Feed speed max.	kW	4x110 - 4x200 (at 1500 1/min)
Drive motors	t	20
Machine weight with drive motors		

SAW SETTING DISTANCES (in mm)

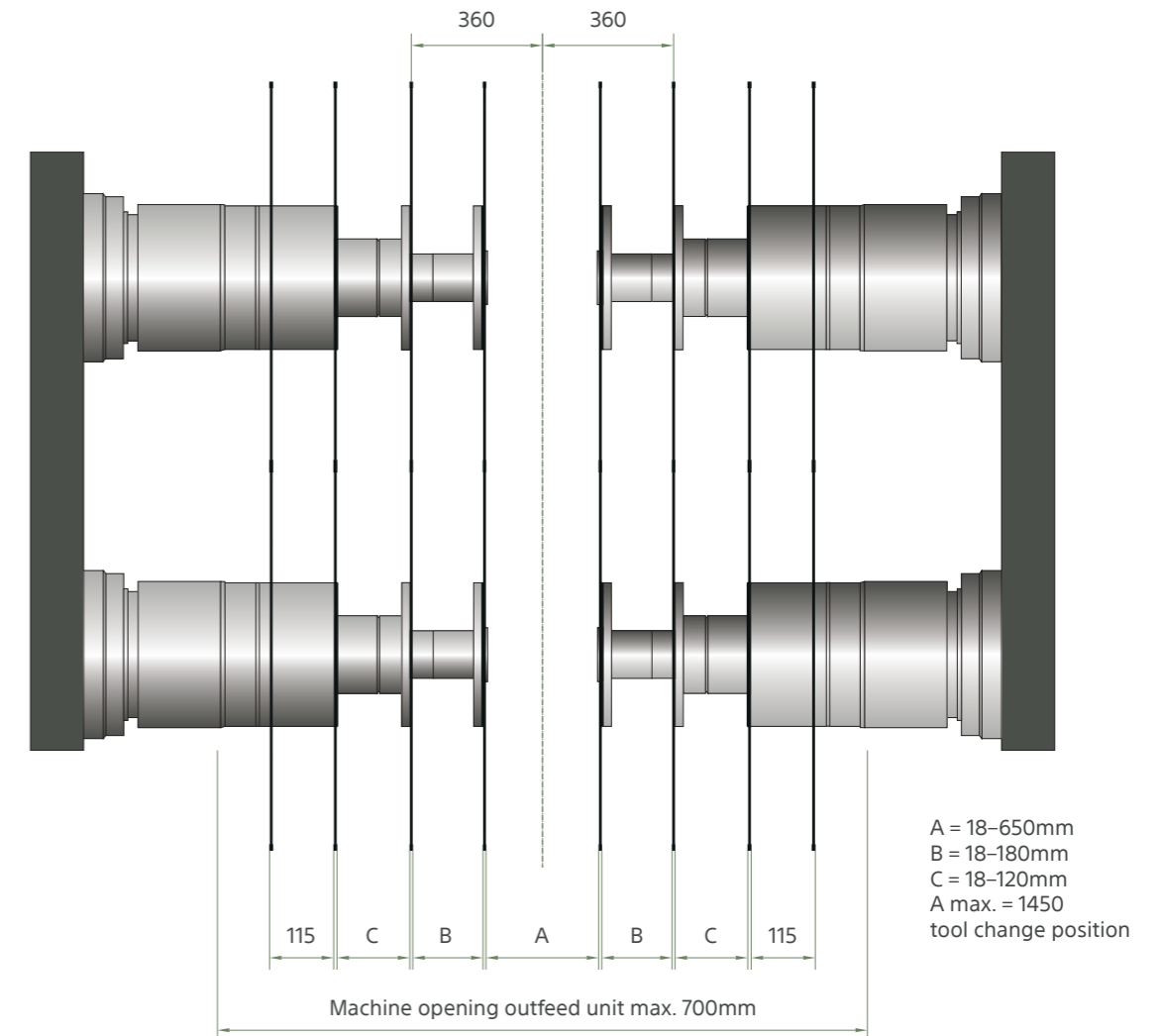

APPLICATION EXAMPLES VNK 300

Primary break down

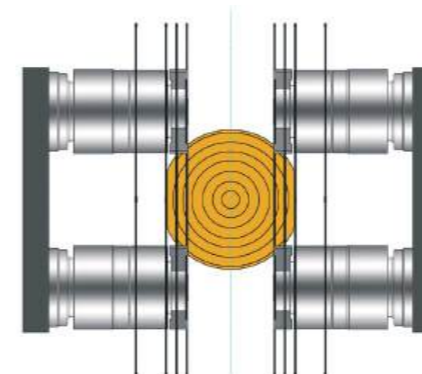

Secondary break down

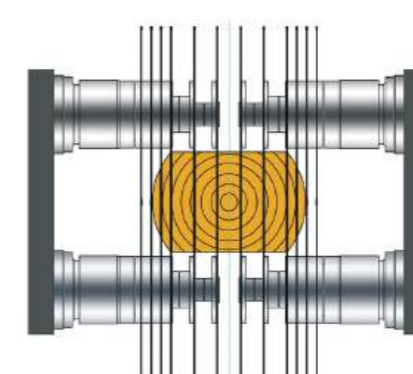

Cant and profile sawing

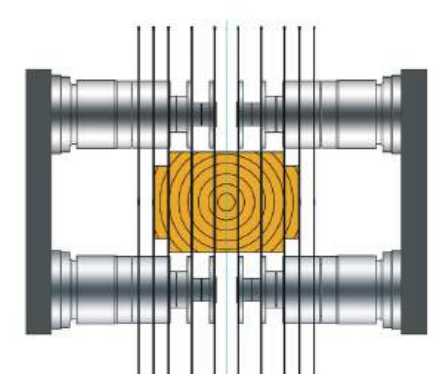

PROFILING AND SAW UNIT FR 16

→ Profiling and sawing with one machine, for scan and set processing

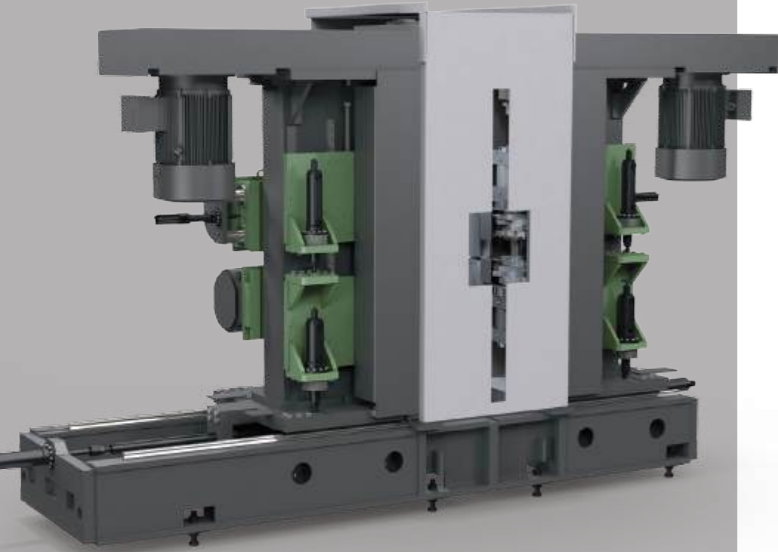

PROFILING AND SAW UNIT FR 16

PROFILING

Allows per side the profiling of one side board. Profiling with vertically arranged profiling heads for variable position and width of the side board. The profiling heads may be fitted for a variable chip length of up to 30mm with 2 or 4 knives on the tool circumference. For the production of pellet chips and for lumber without fibre tear out and extraordinary long tool usage times the P-System heads, developed together with LEUCO, will be used.

SAWING OFF

Up to 2 side boards per side may be sawn off from a log or 2-sided cant with the double arbor circular saw module. In the standard version, the inner side board thickness is fix set, using spacer rings. For a flexible thickness of the inner side board an optional saw arbor with telescopic inner saw arbor is available. The horizontal and vertical positioning of profiling heads and saw blades is done by servo-hydraulic networks.

Sliding platform for easy and safe access for tool change and maintenance.

PROFILING AND SAW UNIT Tools - setting distances



PROFILING AND SAW UNIT FR 16

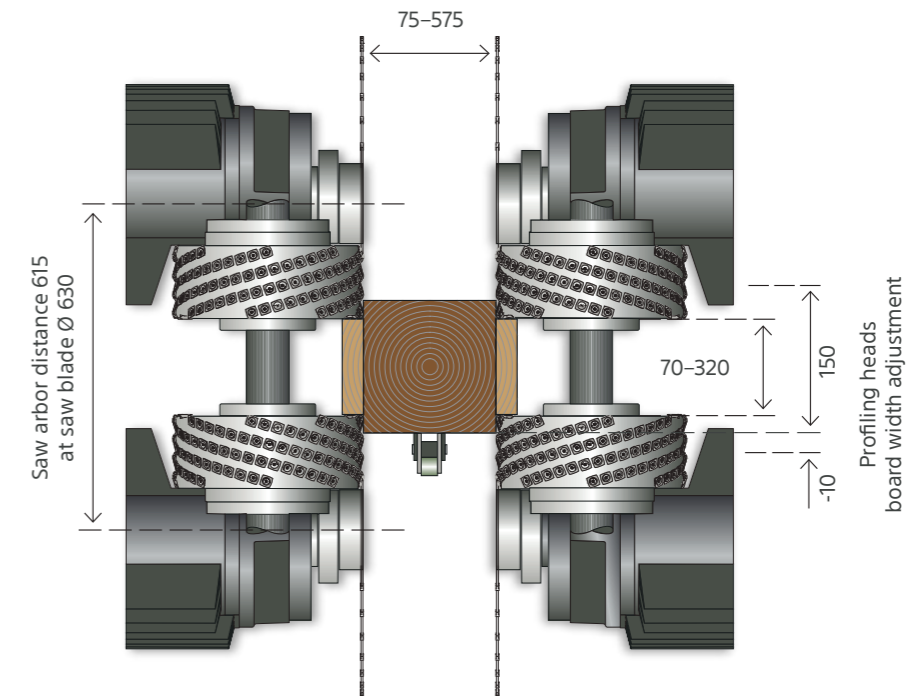

The FR 16 does the profiling and sawing of the side boards in one machine.



TECHNICAL DATA

Log/cant length min.	m	2.4
Drive power profiling heads	kW	2x75-132
Drive power saw motors	kW	4x80-110
Weight with drive motors	t	28
Machine opening tool change	mm	950
Feed speed max.	m/min	150

PROFILING UNIT FR 15 V

→ Profiling with vertically arranged profiling head, for variable position and width of the side board

The FR 15 V profiling unit does the profiling of one side board per side. The frequency controlled profiling is done with vertically arranged profiling heads.

The profiling heads may be fitted for a variable chip length of up to 30mm with 2 or 4 knives on the tool circumference.

For the production of pellet chips and for lumber without fibre tear out and extraordinary long tool usage times, the P-System heads, developed together with LEUCO, will be used.

The horizontal and vertical positioning of profiling heads is done by precision servo-hydraulic networks.

Sliding platform for easy and safe access for tool change and maintenance.

SAW UNIT FR 14

→ Double arbor circular saw for the sawing off of side boards

The FR 14 double arbor circular saw unit can saw up to 2 side boards per side from a log or 2-sided cant. In the standard version, the inner side board thickness is fixed, using spacer rings.

For a flexible thickness, even of the inner side board, an optional saw arbor with telescopic inner saw arbor is available.

The horizontal and vertical positioning of saw blades is done by servo-hydraulic networks.

Sliding platform for easy and safe access for tool change and maintenance.

PROFILING UNIT Tools - setting distances FR 15 V

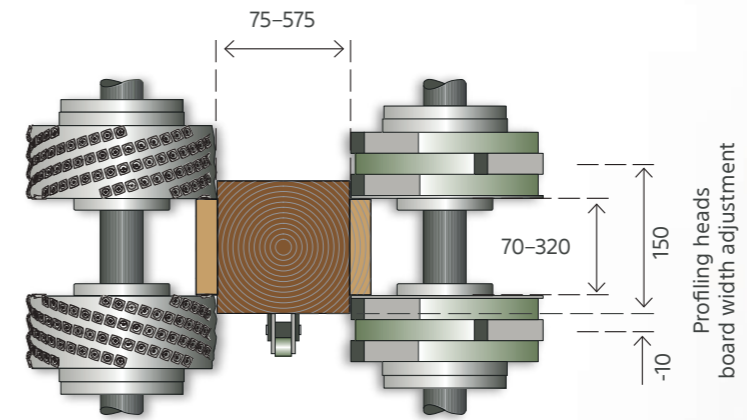

TECHNICAL DATA FR 15 V

Log/cant length min.	m	2.4
Drive power profiling heads	kW	2x75-132
Weight with drive motors	t	16
Machine opening tool change	mm	950
Feed speed max.	m/min	150

TECHNICAL DATA FR 14 V

Log/cant length min.	m	2.4
drive power saw motors	kW	4x80-110
Weight with drive motors	t	17
Machine opening tool change	mm	950
Feed speed max.	m/min	150

Fix sleeve length for 3rd and 4th side board
Side board thickness max. 50mm

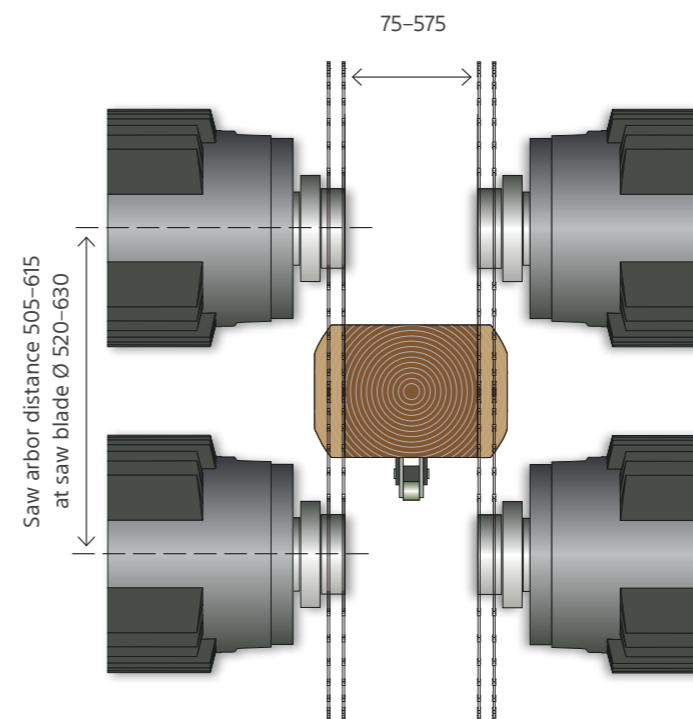

PROFILING UNIT FR 15 H

→ Profiling with horizontally arranged profiling head, for variable position and width of the side board

The profiling unit FR 15 H does the profiling of one side board per side. The profiling is performed through the horizontal profiling heads. The profiling heads may be fitted for a variable chip length of up to 30mm with 2 or 4 knives on the tool circumference. For the production of pellet chips and for lumber without fibre tear out and extraordinary long tool usage times, the P-System heads, developed together with LEUCO, will be used. The horizontal and vertical positioning of profiling heads is done by precision servo-hydraulic networks.

The profiling unit FR 15 H can perform diagonal profiling of the boards, relative to the transport level at full feed speed to achieve an even higher recovery.

Sliding platform for easy and safe access for tool change and maintenance.

PROFILING UNIT Tools - setting distances FR 15 H

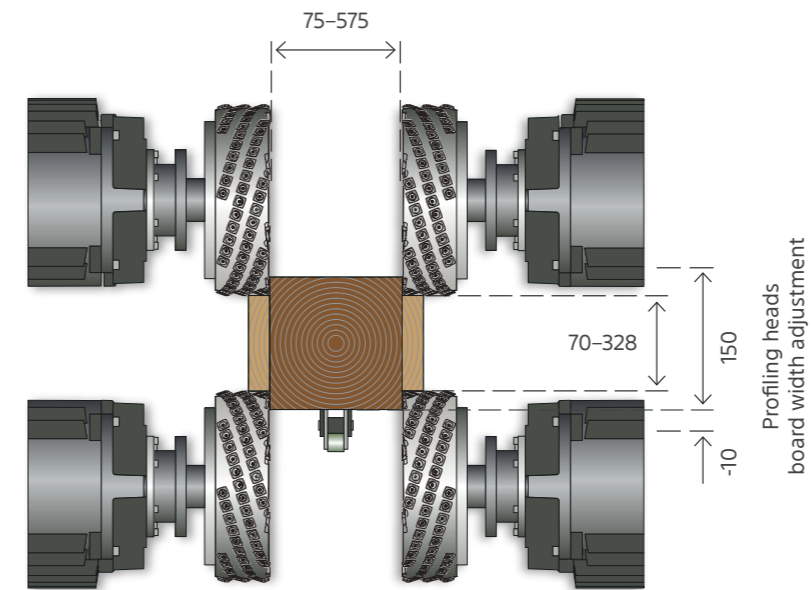

TECHNICAL DATA FR 15 H

Log/cant length min.	m	2.4
Drive power profiling heads	kW	4x50-65
Weight with drive motors	t	13
Machine opening tool change	mm	950
Feed speed max.	m/min	150

TECHNICAL DATA FR 15 M

For fix board width and variable board position.

Cant length min.	m	1.5
Drive power	kW	4x45
Weight with drive motors	t	8
Feed speed max.	m/min	100

EWD



PROFILING UNIT FR 15 S

→ Profiling with vertically arranged profiling heads and preceding notching saws

The pulp and paper industry requires for their process optimisation and the best paper quality a high and homogenous chip quality. The use of preceding notching saws avoids the generation of "comma" chips. The profiling chips produced by the FR 15 S reach the maximum chip quality achievable for this process.

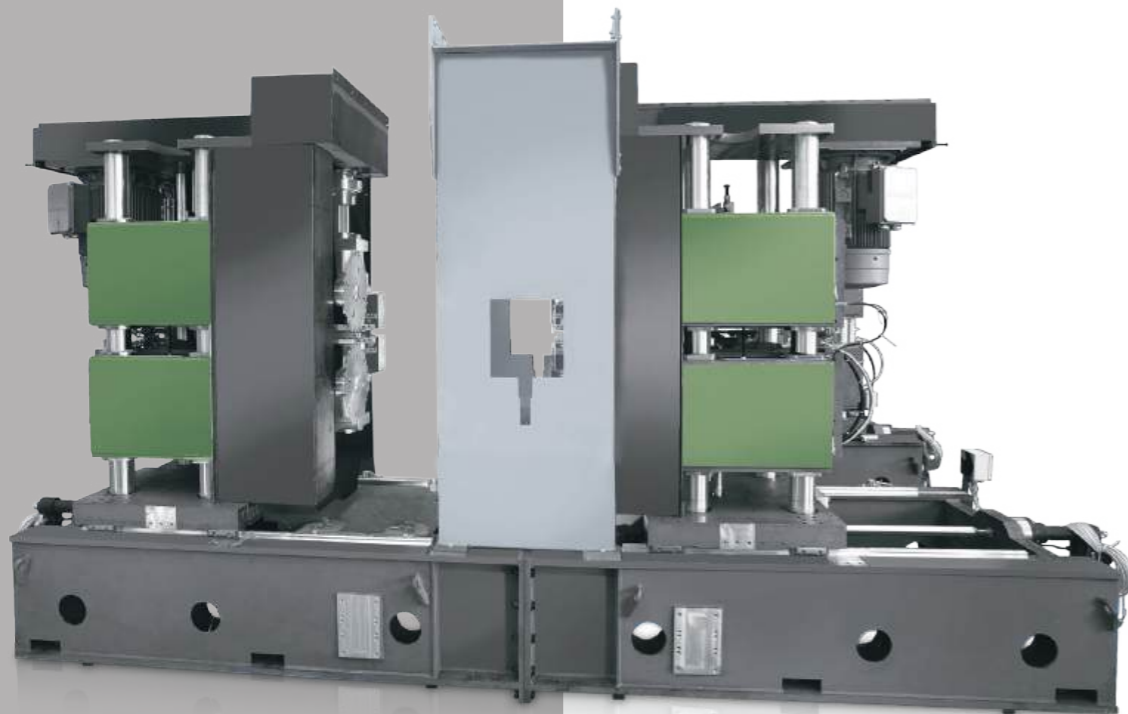

PROFILING UNIT Tools - setting distances FR 15 S

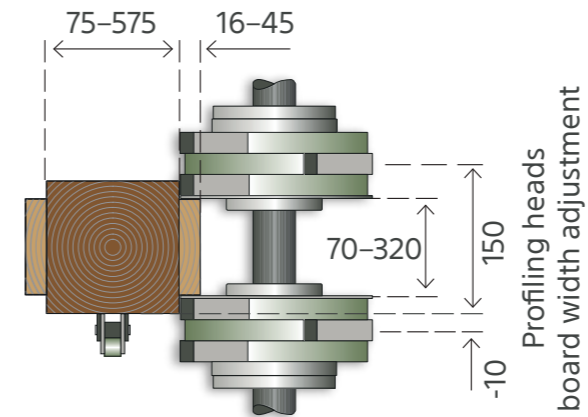

TECHNICAL DATA

Log/cant length min.	m	2.4
Drive power saw motors	kW	4x50-65
Drive power profiling heads	kW	2x75-132
Weight with drive motors	t	26
Machine opening tool change	mm	950
Feed speed max.	m/min	200



For the individual optimum recovery of each side board, the profiling unit FR 15 S can perform diagonal profiling of the boards. The profiling heads are positioned for each board individually, based on the 3D scanner data and optimisation results. The precise closed loop motion control system allows achieving the maximum recovery while always using the maximum wane allowance programmed.

Sliding platform for easy and safe access for tool change and maintenance.

NKU 150

Saw arbors individually adjustable in height

RESAW NKU 150

Double arbor circular resaw with fix-mounted saw blades



OPERATING SIDE VIEW

The NKU 150 unit is designed for short lumber length and small saw kerfs for sawing heights up to 160mm. The solid and robust design is exceptional for this application and allows the use of powerful drive motors, giving superior performance with highest reliability and precision.



Use your phone or tablet to scan this QR Code and see the NKU in action.

DRIVE MOTOR SIDE VIEW

The electric-driven individual height adjustment of the saw arbors allows to spread the sawing height evenly on the top and bottom saw blades and also the use of the optimum saw blade diameter.

SAW SETTING DISTANCES

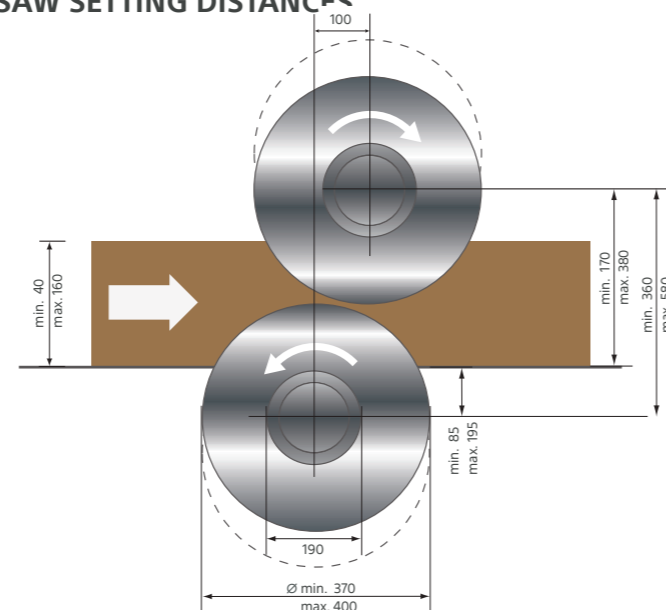

INFEEED SIDE

EWD's machinery programme provides positioning and infeed systems to suit all applications and installation situations.

OUTFEED SIDE

Outfeed and side board separation systems are available for the NKU 150 according to the required tasks.

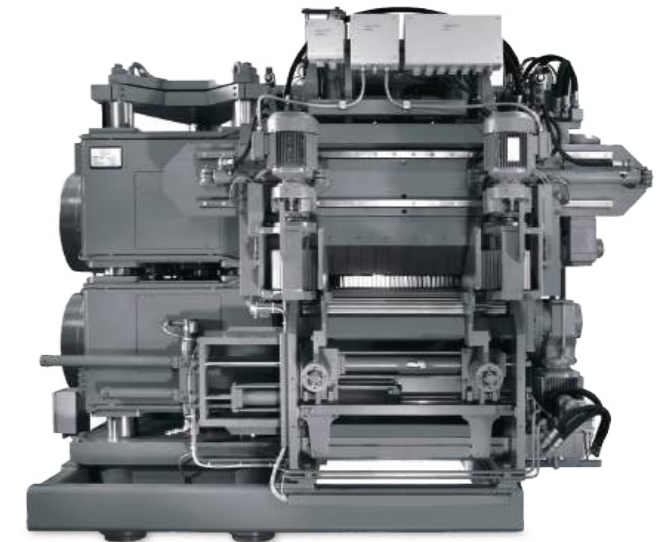
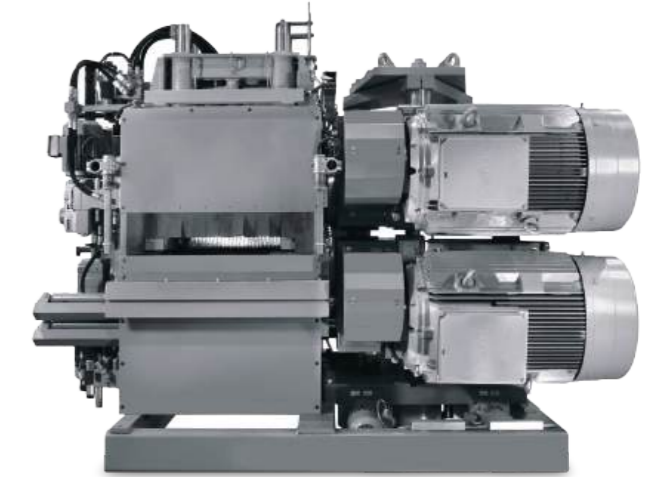

TECHNICAL DATA

Sawing height	mm	40-160
Passage height max.	mm	180
Cant length min.	m	1.0
Cant width max.	mm	620
Useable saw sleeve length	mm	615
Machine opening infeed (with lumber guide)	mm	625
Machine opening cutfeed	mm	900
Saw blade diameter top and bottom	mm	370-400
Saw arbor diameter	mm	110
Drive motor size	kW	2 x 160
Feed speed max.	m/min	100
Weight without motors approx.	t	12

NKU 250

Saw arbors individually adjustable in height



The NKU 250 is designed for lumber production with the highest accuracy and precision

The machine is used in medium to large sawmills.

EWD offers alignment and infeed devices for all applications and installation solutions.

The NKU 250 is characterised by its uniquely strong construction which enables the use of high output motors. EWD guarantees an outstanding performance with the highest reliability and precision.

TECHNICAL DATA

Sawing height	mm	50–250
Passage height max.	mm	50–280
Lumber length min.	m	1.5
Cant width	mm	75–600
Useable saw sleeve length	mm	600
Infeed width with lumber guide bars	mm	620
Outfeed	mm	900
Saw blade diameter top and bottom	mm	460–500
Saw arbor diameter	mm	110
Drive motor size max.	kW	200
Feed speed max.	m/min	40–160
Saw arbor revolutions	1/min	2800
Saw arbor height adjustment bottom (hydr.)	mm	180
Saw arbor height adjustment top (electr.)	mm	380
Dimensions		
Length, without motors approx.	mm	1920
Width, without motors approx.	mm	2850
Height approx.	mm	2400
Weight without motors approx.	t	12

RESAW NKU 250

Double arbor circular resaw with fix-mounted saw blades

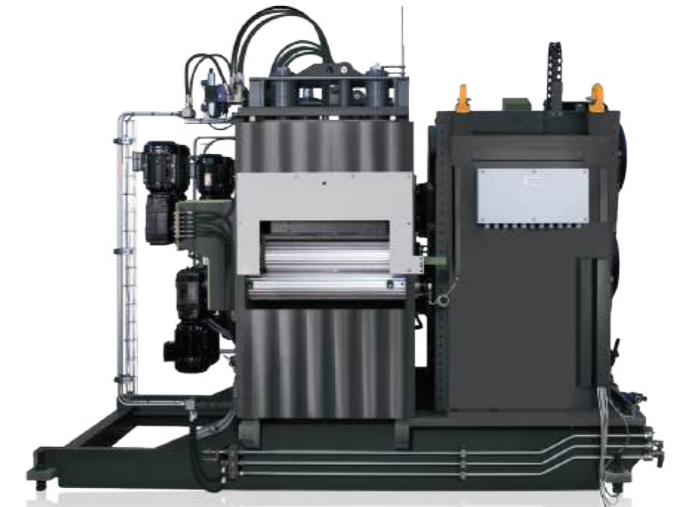
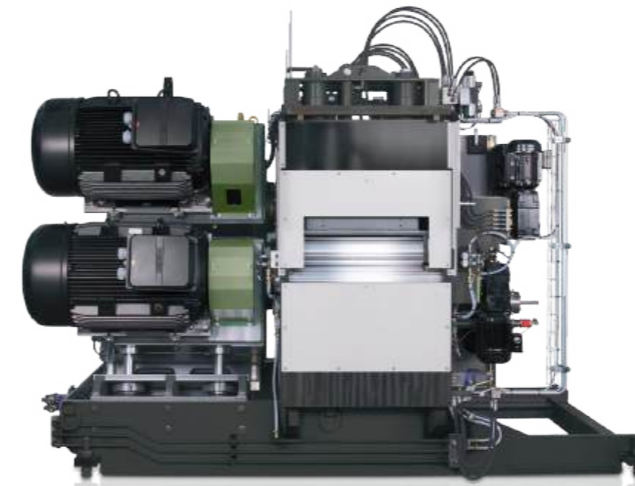

HORIZONTAL DOUBLE ARBOR RESAW FVHTK

TECHNICAL DATA

Passage opening max.	mm	500 x 500
Sawing depth max.	mm	360
Saw blade diameter	mm	610
Lifting height saws		
drive motors max.	mm	360
telescopic arbors max	mm	150
Drive motor size	kW	2x80 or 110



NKV 300

Flexibility through the movable flanges



SINGLE ARBOR CUT

Using the combined single arbor cut, production can be made with flanges positioned towards one another on the upper and lower side (fixed and movable) and arbor independent blade adjustment.

The number of horizontal and vertical cuts can get changed by two products. In addition to the fixed dimensions two cuts of variable thicknesses from 18 to 120mm can be created.

DOUBLE ARBOR CUT

In the double arbor cut (the upper and lower arbor are in the same saw kerf) fixed and movable flanges are synchronously adjusted.

This allows the change of the number of the main products by one product. This cut can vary in width from 18 to 120mm.

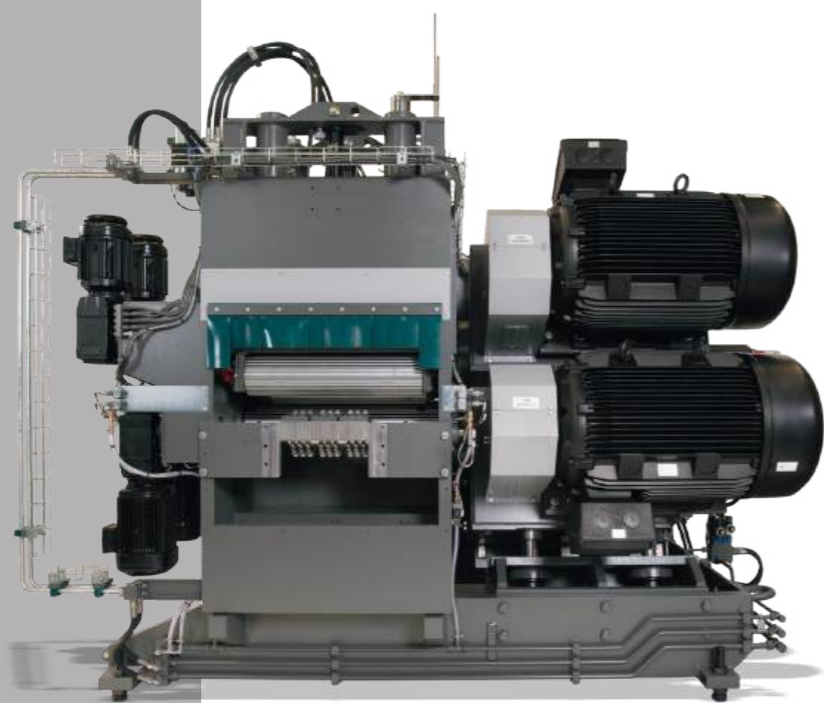

RESAW NKV 300

Technical data



TECHNICAL DATA

Sawing height	mm	50-300
Passage height max.	mm	50-320
Lumber length min.	m	2.0
Cant width	mm	75-600
Useable saw sleeve length	mm	550
Infeed width with lumber guide bars	mm	620
Outfeed	mm	900
Saw blade diameter top and bottom	mm	500-590
Saw arbor diameter	mm	110
Drive motor size max.	kW	200
Feed speed max.	m/min	40-160
Saw arbor revolutions	1/min	2800
Saw arbor height adjustment bottom (hydr.)	mm	180
Saw arbor height adjustment top (electr.)	mm	380

System product change fixed tools Adjustment system, servo-hydraulic

Dimensions		
Length, without motors approx.	mm	1920
Width, without motors approx.	mm	2850
Height approx.	mm	2400
Weight without motors approx.	t	12



REDUCING LINE WITH MERRY-GO-ROUND

Example 1



Compact reducer line with a double arbor circular saw DWK as the main break down machine.

In primary break down up to 6 side boards of variable thickness and one variable centre cant thickness can be sawn.

In secondary break down up to 7 centre products of variable thickness can be sawn. The outer saw heads can be fitted with fix-mounted saws on saw sleeves.

The standard line is designed for log length from 2.5 to 6m and a maximum log diameter of 75cm, including taper and sweep.

Feed speed range from 25 to 120 m/min.
Length of the reducing line: approx. 56m

MESS 3D

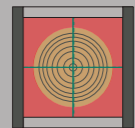

ZE



PF 19

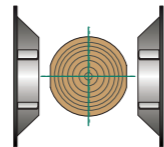

DWK

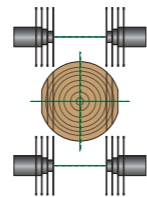

BA

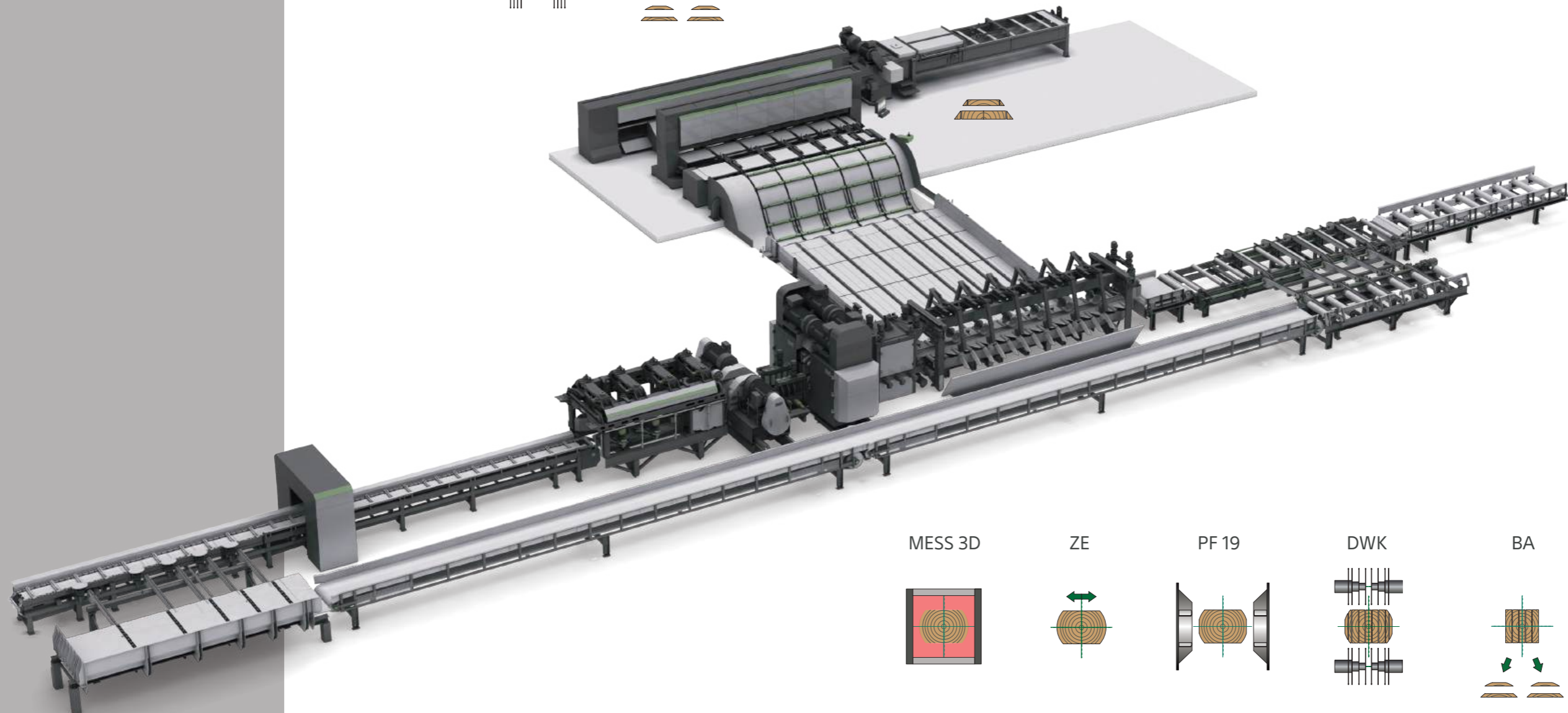
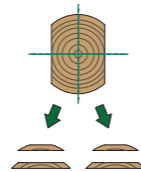

MESS 3D

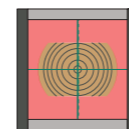

ZE

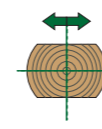

PF 19

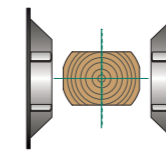

DWK

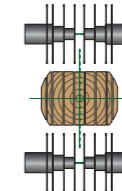

BA

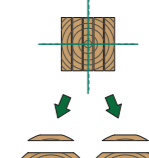

COMPACT PROFILING LINE

Example 1



Compact profiling line for 2 + 2 side boards, with upgrade possibility to 4 + 4 side boards. For log length of 2.5 to 6.1 m and a log diameter of max. 55cm, including taper and sweep.

The line is designed for scan and set sawing, adjusting the tools from log to log. Maximum 5-centre products of variable thickness. Side boards variable in thickness, width and position. Length of the profiling line: approx. 64m.

MESS 3D

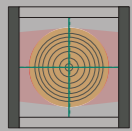

ZE

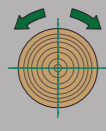

FZ1

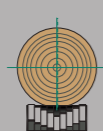

PF 19

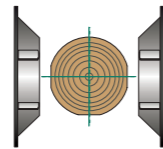

FR 16

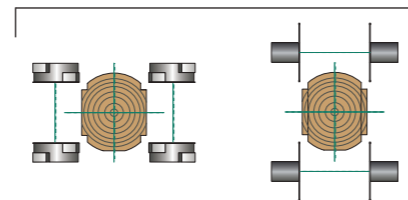

TTS / TDP

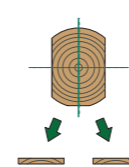

TKV

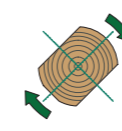

ZE

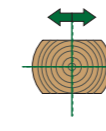

PF 19

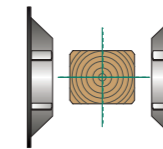

FR 15 H

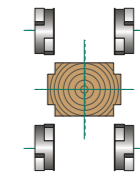

DWK

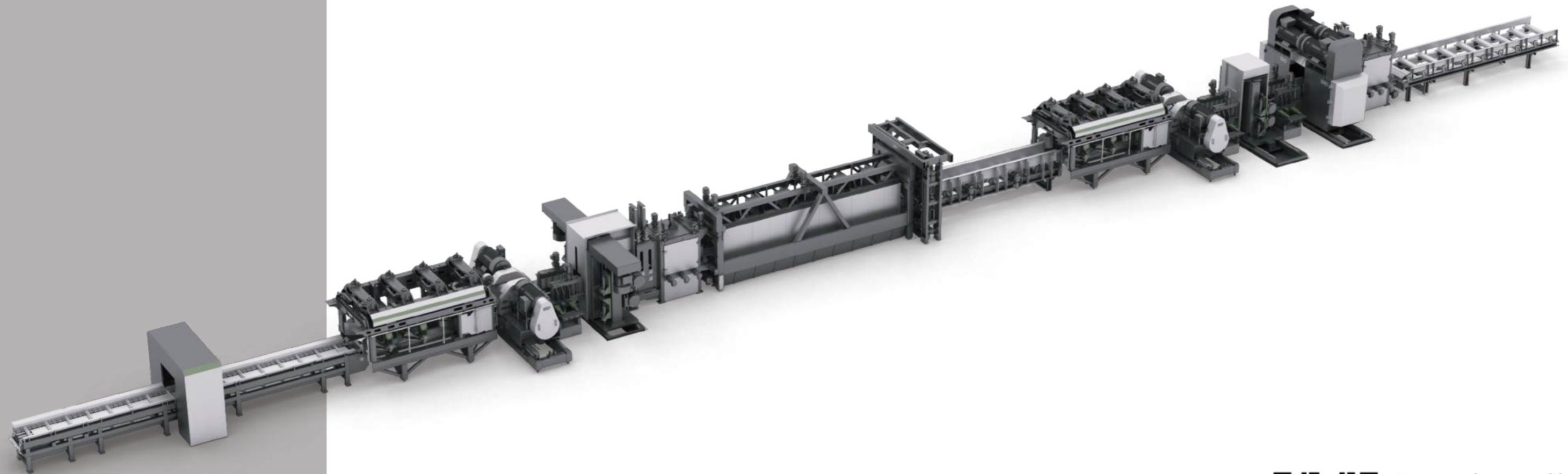
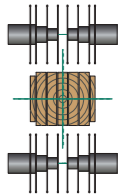

Use your phone or tablet to scan this QR Code and see the Profiling Line in action.

COMPACT PROFILING LINE

Example 2



Compact profiling line for 2 + 2 side boards, with separate vertical and horizontal resaw station for the centre product, with upgrade possibility to 4 + 4 side boards.

For log length of 2.5 to 6.1m and a log diameter of max. 55cm, including taper and sweep.

The line is designed for scan and set sawing, adjusting the tools from log to log. Maximum 5-centre products of variable thickness for vertical resawing and 3 products for horizontal resawing.

Side boards variable in thickness, width and position. Length of the profiling line: approx. 78m.

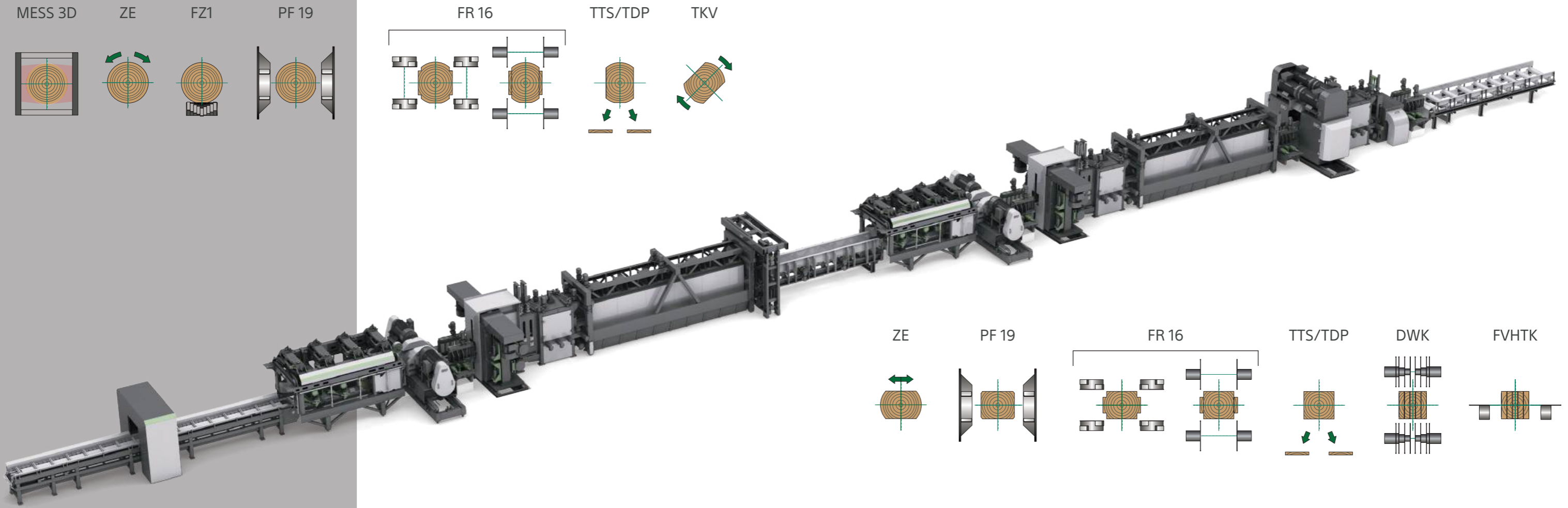

Use your phone or tablet to scan this QR Code and see the Profiling Line in action.

CLASSIC "CHIP-TURN-CHIP" PROFILING LINE

Example 3



Classic profiling line for 4 + 4 side boards, with separate vertical and horizontal resaw station for the centre product.
For log length of 2.5 to 6.1 m and a log diameter of max. 55cm, including taper and sweep.

The line is designed for scan and set sawing, adjusting the tools from log to log. Maximum 5-centre products of variable thickness for vertical resawing and 3 products for horizontal resawing.
Side boards variable in thickness, width and position.
Length of the profiling line: approx. 114m.

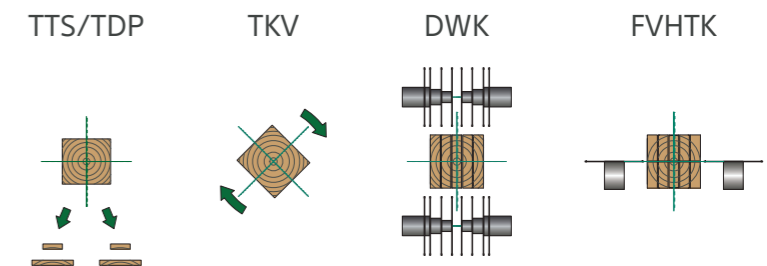
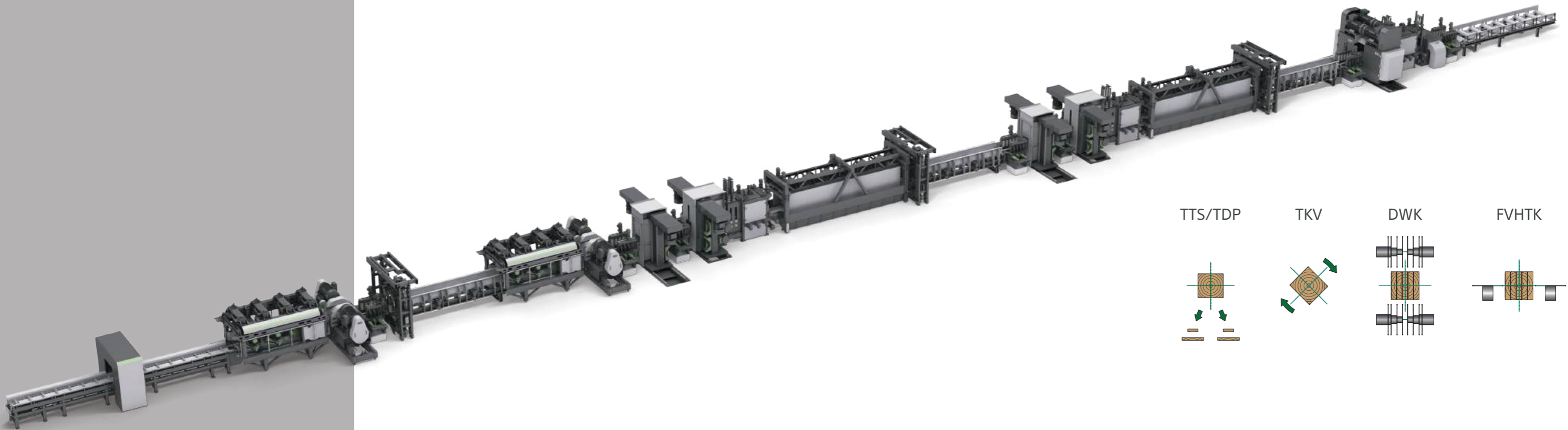
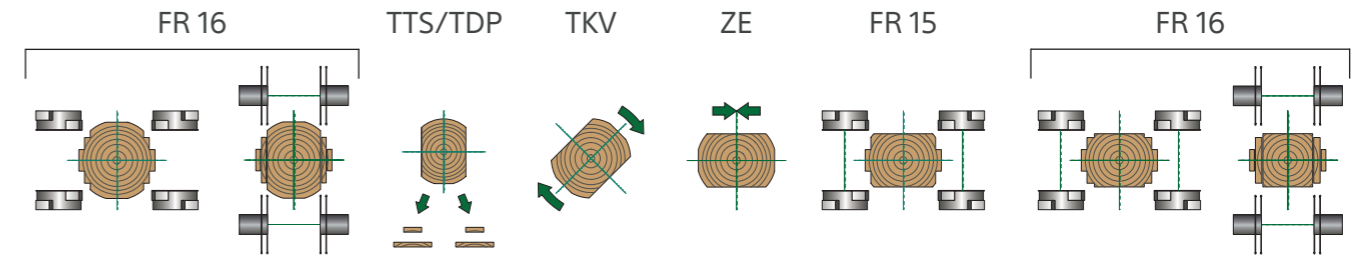
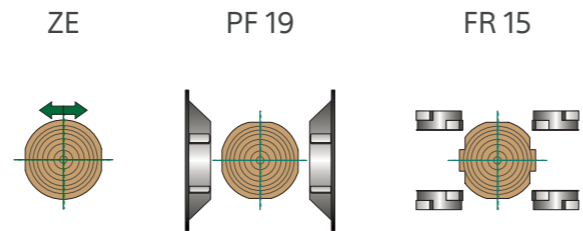
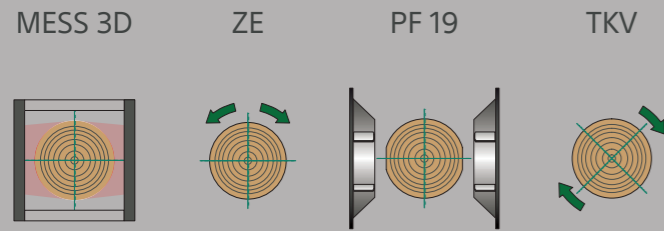

REDUCING-PROFI-LINE

Example 4



→ With Quad bandsaw in primary break down

Combined Reducing and Profiling line, with separate vertical and horizontal resaw station for the centre product.

For log length of 2.5 to 6.1m and a log diameter of max. 75cm, including taper and sweep.

The line is designed for scan and set sawing, adjusting the tools from log to log. Maximum 5-centre products of variable thickness plus fix dimension for vertical resawing and 3 products for horizontal resawing. In primary break down up to 4 side boards of maximum thickness 100mm each can be sawn.

In secondary break down 2 side boards can be profiled up to a thickness of 45mm each. Large logs can be sawn in secondary break down with up to 4 side boards, which will be sent to the optimising edger system.

Length of the Reducing-Profiling line: approx. 77m.

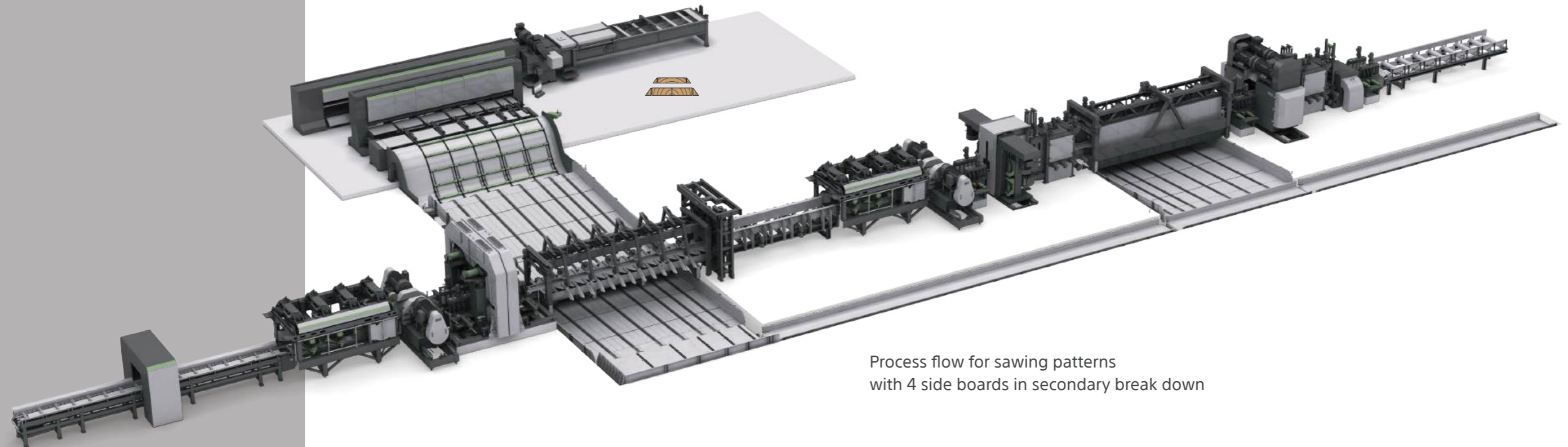

Process flow for sawing patterns with 4 side boards in secondary break down



REDUCING-PROFI-LINE

Example 5



→ With double arbor circular saw unit DWK in primary break down and resawing

Combined Reducing and Profiling line, with separate vertical and horizontal resaw station for the centre product.
For log length of 2.5 to 6.1m and a log diameter of max. 70cm, including taper and sweep.

The line is designed for scan and set sawing, adjusting the tools from log to log. Maximum 5-centre products of variable thickness plus fix dimension for vertical resawing and 3 products for horizontal resawing. In primary break down up to 6 side boards can be sawn.

In secondary break down 2 side boards can be profiled up to a thickness of 45mm each. Large logs can be sawn in secondary break down with up to 4 side boards, which will be sent to the optimising edger system.
Length of the Reducing-Profiling line: approx. 78m.

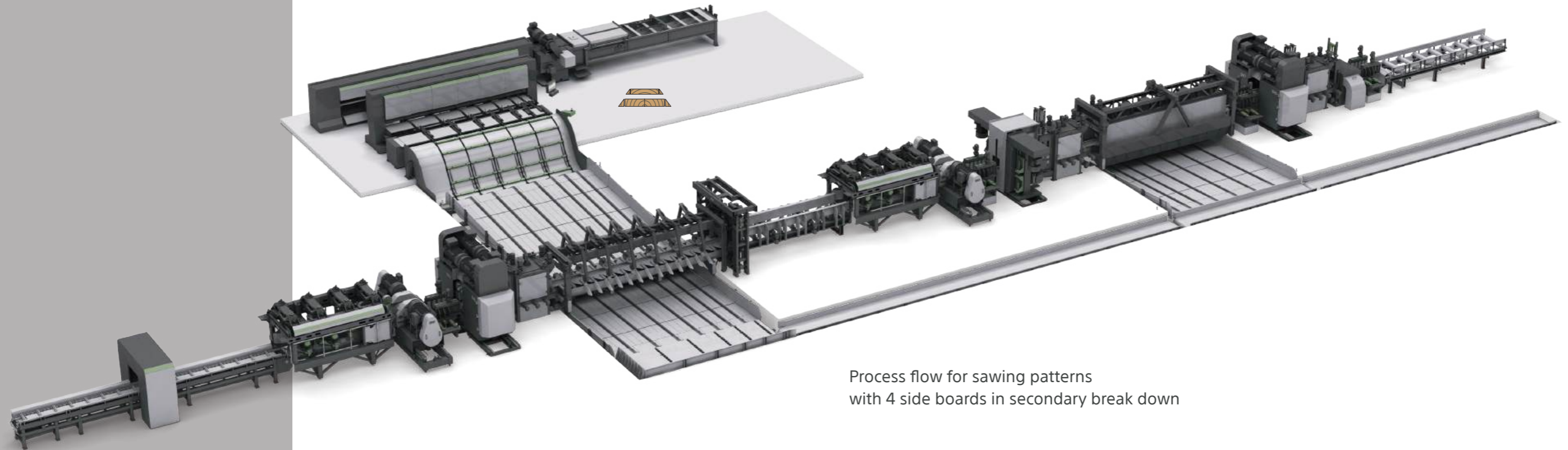

Process flow for sawing patterns with 4 side boards in secondary break down





EWD

Esterer WD GmbH
Estererstraße 12
D - 84503 Altötting

T +49 8671 503 0
F +49 8671 503 386

Markwiesenstraße 40
D - 72770 Reutlingen

T +49 7121 5665 0
F +49 7121 5665 400

info@ewd.de