



SASH GANG TECHNOLOGY

EWD

EWD TYPES OF SASH GANGS

Cost-efficient sash gangs for the use in all sawmill sizes



LSH | 500 STROKE

For the use in small to medium-sized sawmills. Light-weight sash gang for various applications.



HDE-S | 500 STROKE

For the use in medium-sized sawmills. Sturdy design in this performance class.



HDN / GDZGE | 600 STROKE

For medium to higher sawing capacities. For all diameter ranges and all soft and hard woods. Also available with 8 rollers for short logs.



HDSN | 600 AND 700 STROKE

For higher sawing capacities at highest feed speeds.

ROBUST CONSTRUCTION AND SIMPLE OPERATION

All EWD sash gang saws impress with their mature and durable construction. A clearly arranged machine design with easily accessible components allows easy maintenance and servicing of the machine. The flywheel can be changed on the sash gang types LSH, HDE-S, HDN and HDSN without dismantling the side frames. The side frames are made of a stable, torsion resistant cast iron construction. The crank pin and the flywheel shaft are made of special steel. All parts, especially the highly stressed connecting rods and sash beams, are subject to constant quality controls during production.

WIDTH ADJUSTMENT

The sash gang types GDZGE, HDN and HDSN are available with a hydraulic and electric width adjustment. Optionally they are also available with the VARIO SV4 quad width adjustment. The sash gang types HDE and LSH are available with a double width adjustment.

FEED SPEED CONTROL DEPENDING ON THE PERFORMANCE

The feed speed is always defined by the operator. If the power consumption is too high, the feed speed is automatically reduced.

AUTOMATIC CALCULATION OF THE CUTTING VOLUME

Display of the cutting volume on the operating panel with possibility to record on an external storage device.

POWER MONITORING

The motor currents of the main drive motor are monitored to protect the machine/tools from damage in case of overload (exceeding the current limit). The measured values are shown on the display or can be read out via remote maintenance.

PLC CONTROL

The electrical signals from the installation, from the control panel and from the control cabinet are linked by means of PLC sequence control. Remote maintenance access is possible.

ADDITIONAL EQUIPMENT FOR ALL EWD SASH GANGS

- USF Remote controlled log feed system
- ZE-F Centering and infeed table
- KSB Sideboard cross cut saw
- AVER Outfeed and splitting device

„LIVE VIEW“ DISPLAY OF THE CUTTING LINES

Using CCD digital cameras, the products to be processed are displayed in a window on the monitor in real time; with graphic visualization of the products to be processed and data transfer to the PC. CCD colour camera with zoom lens, camera housing with heating. „Live View“ software and colour monitor. The cutting lines are set manually on the corresponding saw blades. Composition of the lines from the center of the sash gang. The cutting lines are projected in the camera image on the monitor. The products between the saws are displayed on the workpiece.

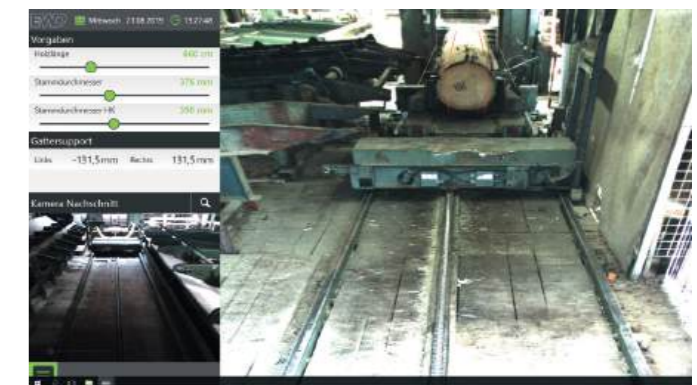

AVER 1550

For the separation of main and side products during breakdown and resawing. Safe guidance of logs, model or prisms to avoid crooked or propeller cut. Removal of processed goods and residues. The AVER splitting key device forms a functional unit with the sash gang in longitudinal cut.

BALANCING UNIT THE ONLY ONE AVAILABLE ON THE MARKET

The balancing unit developed by EWD reduces the inertia forces of first and second order. In this way we can largely avoid the development of disturbing ground vibrations in unfavourable ground conditions.

SERVICE AND AFTER SALES CUSTOMER SERVICE

Seamless customer service, extensive spare parts warehouse, service contracts as carefree packages.

LSH 500 STROKE OSCILLATING FRAME SASH GANG

Cost-efficient sash gang for the use in small to medium-sized sawmills



FEED DRIVE SYSTEM

The sash gang saw is equipped with a hydraulic feed drive with variable speed control over the full feed speed range.

AUTOMATIC OVERHANG ADJUSTMENT

The overhang of the sash frame is automatically adjusted according to the selected feed speed. Maintenance free spindles and worm gears adjust the overhang plates.

OSCILLATING FRAME

The LSH is fitted with an oscillating frame. The combination with the automatic overhang adjustment achieves very advantageous sawing conditions, without rubbing of the saw blades. The ejection of saw dust to the top is eliminated as far as possible and the sawing of large logs is made considerably easier.

ROLLERS

The rollers are split and/or fitted with easily changeable inserts.

FOUNDATION

The sash gang LSH can be placed on the base plates of the predecessor model LD. In the flywheel areas only small modifications are required.

MAIN DRIVE

The sash gang saw is fitted with fix and idle pulleys for the shifting of the drive belt.

TECHNICAL DATA AND DETAILS

LSH | 500 stroke

HYDRAULIC SYSTEM

The lifting and lowering and the drive of the feed rollers use hydraulic power. The hydraulic system is composed of standard components, using a modular principle. All parts such as electric motors, pumps and valves are grouped in a central hydraulic system, separated from the sash gang saw and easily accessible.

The saw dust shaker and the central lubrication system have separate drives and therefore can be used even when the machine is not running.

HYDRAULIC SHIFTING SAW BANKS

Optionally the sash gang LSH is available with a symmetric hydraulic shifting saw bank system „SV“. The adjustment of the saw banks is possible from the operator control panel during normal operation.

ADJUSTMENT RANGE WIDTH ADJUSTMENT

x1 : max. mm 140
x2 : min. mm 40 without MS center split saw
x2 : min. mm 65 with MS center split saw
x2 : max. mm 280

ADDITIONAL EQUIPMENT

- USF Remote controlled log feed system
- ZE-F Centering and infeed table
- KSB Sideboard cross cut saw
- AVER Outfeed and splitting device
- MAS Balancing unit

TECHNICAL DATA

		LSH
Sash width	mm	650
Sash clearance	mm	90 -620
Stroke	mm	500
Revolutions max.	1/min.	300
Feed speed	m/min.	0-8
Feed power	kW	3,5
Drive pulley ø	mm	900
Main drive motor	kW	55
Machine weight	t	5,4

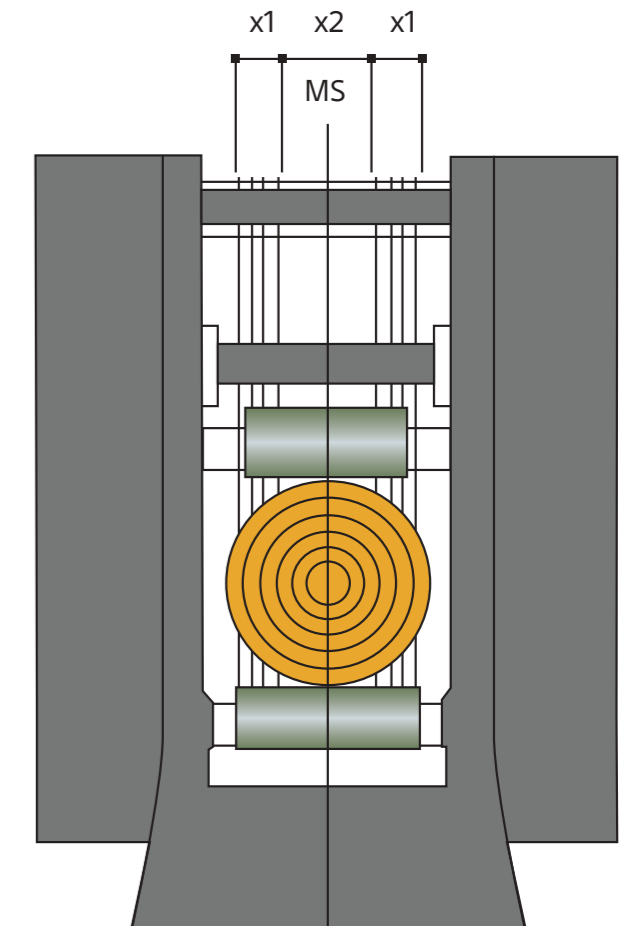

HDE-S | 500 STROKE OSCILLATING FRAME SASH GANG

Cost-efficient sash gang for the use in medium-sized sawmills

TECHNICAL DATA AND DETAILS

HDE-S | 500 stroke



FEED DRIVE SYSTEM

The sash gang saw is equipped with a hydraulic feed drive with variable speed control over the full feed speed range.

AUTOMATIC OVERHANG ADJUSTMENT

The overhang of the sash frame is automatically adjusted according to the selected feed speed. Maintenance free spindles and worm gears adjust the overhang plates.

OSCILLATING FRAME

The HDE-S is fitted with an oscillating frame. The combination with the automatic overhang adjustment achieves very advantageous sawing conditions, without rubbing of the saw blades. The ejection of saw dust to the top is eliminated as far as possible and the sawing of large logs is made considerably easier.

ROLLERS

The hardened rollers are split and easily changeable. Besides the model with 4 feed rollers a model with 8 feed rollers for the sawing of short logs (min. 1 m) or for curve sawing is available.

FOUNDATION

The sash gang HDE-S can be fitted on the foundation of the models S71 / SS71.

MAIN DRIVE

The sash gang saw is fitted with fix and idle pulleys for the shifting of the drive belt.

HYDRAULIC SYSTEM

The lifting and lowering and the drive of the feed rollers uses hydraulic power. The hydraulic system is composed of standard components, using a modular principle. All parts such as electric motors, pumps and valves are grouped in a central hydraulic system, separated from the sash gang saw and easily accessible.

The saw dust shaker and the central lubrication system have separate drives and therefore can be used even when the machine is not running.

HYDRAULIC SHIFTING SAW BANKS

Optionally the sash gang HDE-S is available with a symmetric hydraulic shifting saw bank system „SV“. The adjustment of the saw banks is possible from the operator control panel during normal operation.

ADJUSTMENT RANGE WIDTH ADJUSTMENT

x1 : max. mm 140
 x2 : min. mm 40 without MS center split saw
 x2 : min. mm 65 with MS center split saw
 x2 : max. mm 340

ADDITIONAL EQUIPMENT

- USF Remote controlled log feed system
- ZE-F Centering and infeed table
- KSB Sideboard cross cut saw
- AVER Outfeed and splitting device
- MAS Balancing unit

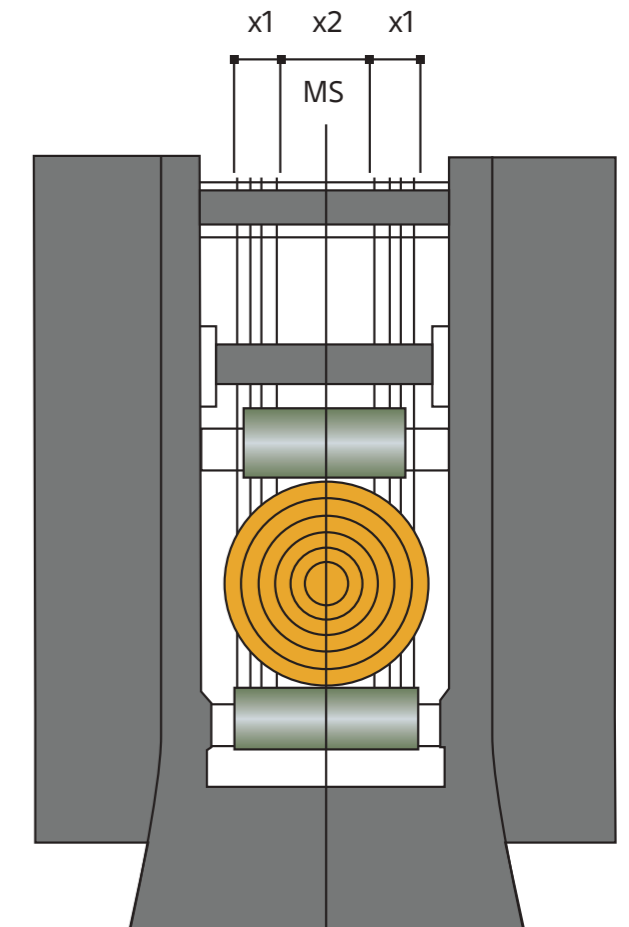

TECHNICAL DATA

		HDE-S	HDE-S/SV	HDE 56
Sash width	mm	700	700	560
Sash clearance	mm	670	670	550
Stroke	mm	500	500	500
Revolutions max.	1/min.	310	300	340
Feed speed	m/min.	0-13	0-12	0-16
Feed power	kW	7	6,5	7
Drive pulley ø	mm	1000	1000	900
Main drive motor	kW	75	75	75
Machine weight	t	8,6	9	8,7

HDN | 600 STROKE OSCILLATING FRAME SASH GANG

Heavy-duty sash gang for the use in medium to large sawmills



FEED DRIVE SYSTEM

The sash gang saw is equipped with a hydraulic feed drive with variable speed control over the full speed range. In combination with the automatic overhang adjustment the feed speed for an optimum relation between saw speed and relative feed speed is achieved. The rubbing of the saw blades is eliminated as much as possible which results in a good lumber surface quality.

AUTOMATIC OVERHANG ADJUSTMENT

The overhang of the sash frame is automatically adjusted according to the selected feed speed. Maintenance free spindles and worm gears adjust the overhang plates.

UPPER SASH GUIDES

The upper sash guides are water-cooled by a cooling unit and a closed water circuit to reduce wear and ensure smooth running of the machine.

ROLLERS

The rollers are split and/or fitted with easily changeable inserts.

FOUNDATION

The sash gang HDN has the same spacing of the anchor bolts as the models SS71 and HDE. For an exchange the minimum foundation volume required must be observed.

MAIN DRIVE

Up to 110 kW drive motors, the sash gang HDN is fitted with fix and idle pulleys for shifting of the drive belt. For bigger drive motors (up to 160 kW) the sash gang saw is fitted with a fix pulley for direct drive.

TECHNICAL DATA AND DETAILS

HDN | 600 stroke

HYDRAULIC SYSTEM

The lifting and lowering and the drive of the feed rollers uses hydraulic power. The hydraulic system is composed of standard components, using a modular principle. All parts such as electric motors, pumps and valves are grouped in a central hydraulic system, separated from the sash gang saw and easily accessible.

The saw dust shaker and the central lubrication system have separate drives and therefore can be used even when the machine is not running.

HYDRAULIC SHIFTING SAW BANKS

Optionally the sash gang HDN is available with a symmetric hydraulic shifting saw bank system „SV“. Optionally also available with the Vario SV4 quad width adjustment. The adjustment of the saw banks is possible from the operator control panel during normal operation.

ADJUSTMENT RANGE WIDTH ADJUSTMENT

x1 : max. mm 140
 x2 : min. mm 40 without MS center split saw
 x2 : min. mm 65 with MS center split saw
 x2 : max. mm 350

ADDITIONAL EQUIPMENT HDN

- USF Remote controlled log feed system
- ZE-F Centering and infeed table
- KSB Sideboard cross cut saw
- AVER Outfeed and splitting device
- MAS Balancing unit

TECHNICAL DATA

		HDN	HDN/SV*
Sash width	mm	730	730
Sash clearance	mm	700	690
Stroke	mm	600	600
Revolutions max.	1/min.	320	300
Feed speed	m/min.	0-15	0-13
Feed power	kW	8,5	6,5
Drive pulley ø	mm	1000	800
Main drive motor max.	kW	160	160
Machine weight	t	12	12

* with shifting saw banks

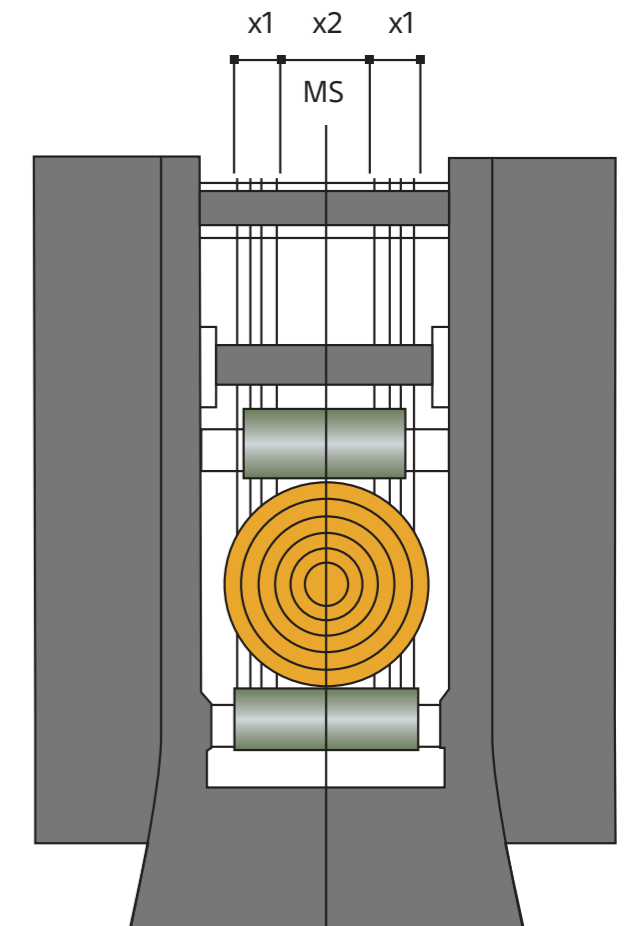

GDZGE | 600 STROKE OSCILLATING FRAME SASH GANG

For best surface qualities and high feed speed



OSCILLATING FRAME SASH GANG

Excellent smoothness and longer lifetime of the sawblade



FEED DRIVE SYSTEM

The sash gang saw is equipped with a hydraulic feed drive with variable speed control over the full feed speed range.

AUTOMATIC OVERHANG ADJUSTMENT

The overhang of the sash frame is automatically adjusted according to the selected feed speed.

OSCILLATING FRAME

The oscillating frame of the GDZGE is characterized by the oscillation of the bottom sash guides. The oscillation move is automatically adjusted according to the selected feed speed.

ADVANTAGE OF THE OSCILLATING SASH FRAME

- total utilization of the sash stroke
- without rubbing
- better sawn lumber surface
- extended operating time for the saw blades
- superb smooth running
- reduced power requirement

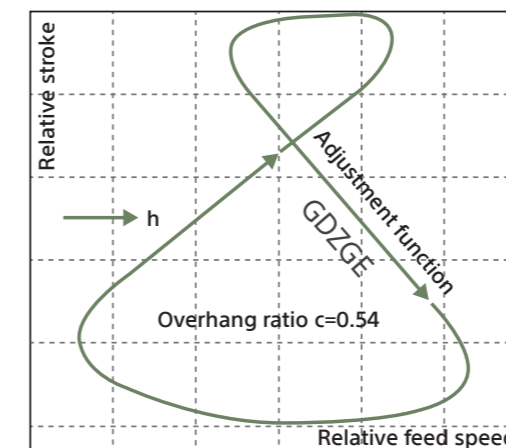

ROLLERS

The rollers are split and/or fitted with easily changeable inserts.

UPPER SASH GUIDES

The upper sash guides are water-cooled by a cooling unit and a closed water circuit to reduce wear and ensure a smooth running of the machine.

HYDRAULIC SYSTEM

The lifting and lowering and the drive of the feed rollers uses hydraulic power. The hydraulic system is composed of standard components, using a modular principle. All parts such as electric motors, pumps and valves are grouped in a central hydraulic system, separated from the sash gang saw and easily accessible.

The saw dust shaker and the central lubrication system have separate drives and therefore can be used even when the machine is not running.

ADDITIONAL EQUIPMENT

- USF Remote controlled log feed system
- ZE-F Centering and infeed table
- KSB Sideboard cross cut saw
- AVER Outfeed and splitting device
- MAS Balancing unit

GDZGE | 600 STROKE OSCILLATING FRAME SASH GANG

For best surface qualities and high feed speed

TECHNICAL DATA AND DETAILS

GDZGE 71 | GDZGE 76



TWO INDIVIDUALLY SHIFTING SAW BANKS

Optionally the sash gang is available with shifting saw banks. Each of the two saw banks is individually adjustable. With one or more center split saws mounted, the saw patterns can be changed from single cant to double cants or multiples without stop and changing of spacers, saws and re-adjustment of the outfeed splitter plates. During the setting of the saw blades in a new position, the outfeed splitter plates open automatically to release the previous sawn log. After that, the plates move automatically in the new set position.

Optionally also available with the Vario SV4 quad width adjustment. The adjustment of the saw banks is possible from the operator control panel during normal operation.

TECHNICAL DATA		GDZGE 71	GDZGE 76
Sash width	mm	710	760
Sash clearance	mm	710	710
Stroke	mm	600	600
Revolutions max.	1/min.	310	310
with shifting saw banks		290	290
Feed speed	m/min.	0-13	0-12
Feed power	kW	7,5	7,5
Drive pulley ø	mm	1000	1000
Main drive motor	kW	90-160	90-160
Machine weight	t	12,8	13,2

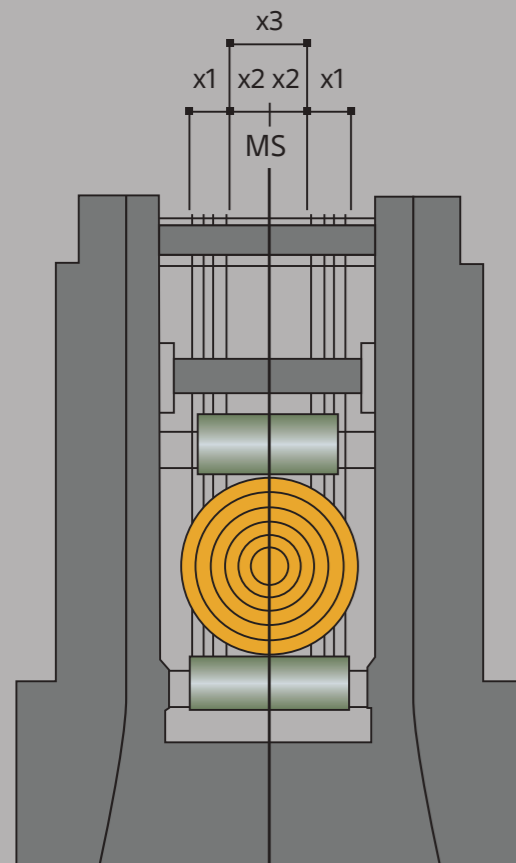

ADJUSTMENT RANGE WIDTH ADJUSTMENT GDZGE 71

MS = Center split saw

x1 : max. (5x18)	mm	5x21.6 = 108
x1 : max. (4x24)	mm	4x27.6 = 110,4
x2 : min. 24 mm	mm	max. 175
x3 : min. 48 mm	mm	max. 353.6
(without MS)		

GDZGE 76

MS = Center split saw

x1 : max. (5x18)	mm	5x21.6 = 108
x1 : max. (4x24)	mm	4x27.6 = 110,4
x2 : min. 24 mm	mm	max. 200
x3 : min. 48 mm	mm	max. 403.6
(without MS)		



HDSN | 600 AND 700 STROKE OSCILLATING FRAME SASH GANG

For highest requirements



FEED DRIVE SYSTEM

The sash gang saw is equipped with a hydraulic feed drive with variable speed control over the full speed range. In combination with the automatic overhang adjustment the feed speed for an optimum relation between saw speed and relative feed speed is achieved. The rubbing of the saw blades is eliminated as much as possible which results in a good lumber surface quality.

AUTOMATIC OVERHANG ADJUSTMENT

The overhang of the sash frame is automatically adjusted according to the selected feed speed. Maintenance free spindles and worm gears adjust the overhang plates.

UPPER SASH GUIDES

The upper sash guides are water-cooled by a cooling unit and a closed water circuit to reduce wear and ensure a smooth running of the machine.

ROLLERS

Besides the model with 4 feed rollers a model with 6 or 8 feed rollers is available.

FOUNDATION

The sash gang HDSN can be placed on the foundation of the models HD30 and EHD30.

MAIN DRIVE

Up to 110 kW drive motors, the sash gang HDSN is fitted with fix and idle pulleys for shifting of the drive belt. For bigger drive motors (up to 160 kW) the sash gang saw is fitted with an enlarged fix pulley for direct drive.

TECHNICAL DATA AND DETAILS

HDSN | 600 and 700 stroke



HYDRAULIC SYSTEM

The lifting and lowering and the drive of the feed rollers uses hydraulic power. The hydraulic system is composed of standard components, using a modular principle. All parts such as electric motors, pumps and valves are grouped in a central hydraulic system, separated from the sash gang saw and easily accessible.

The saw dust shaker and the central lubrication system have separate drive systems and therefore can be used even when the machine is not running.

HYDRAULIC SHIFTING SAW BANKS

Optionally the sash gang HDSN is available with a symmetric hydraulic shifting saw bank system „SV“. Optionally also available with the Vario SV4 quad width adjustment. The adjustment of the saw banks is possible from the operator control panel during normal operation.

ADJUSTMENT RANGE WIDTH ADJUSTMENT

x1 : max.	mm	140	
x2 : min.	mm	40	without MS center split saw
x2 : min.	mm	65	with MS center split saw
x2 : max.	mm	350	

ADDITIONAL EQUIPMENT

- USF Remote controlled log feed system
- ZE-F Centering and infeed table
- KSB Sideboard cross cut saw
- AVER Outfeed and splitting device
- MAS Balancing unit

TECHNICAL DATA

		HDSN	HDSN/SV*
Sash width	mm	735	730
Sash clearance	mm	700	650
Stroke	mm	600/700	600/700
Revolutions max.	1/min.	320	300
Feed speed	m/min.	0-18	0-16
Feed power	kW	10	9
Drive pulley ø	mm	1100	1000
Main drive motor max.	kW	200	200
Machine weight	t	12	12,5

* with shifting saw banks

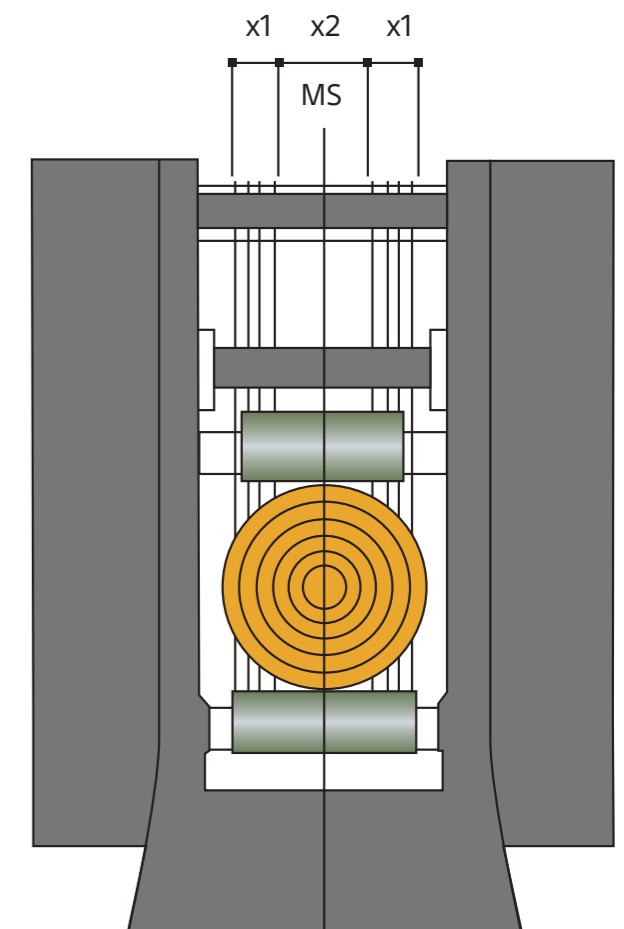

VARIO SV4

Quad electric sawing width adjustment

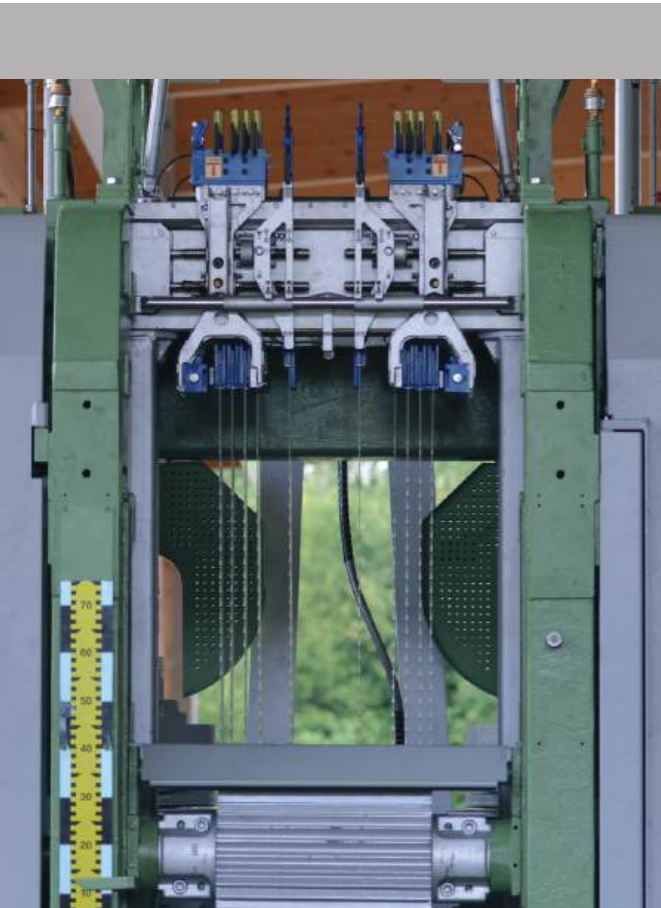

Two saw clusters and two split saws on four independently adjustable spindles enable a rapid switching between live sawing and sawing one, two or three products.

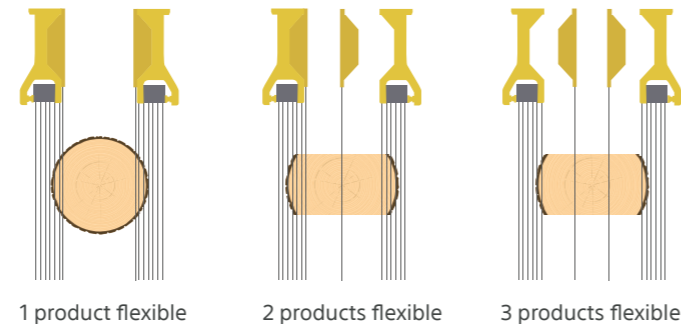

In case of cutting patterns with four products a center split saw can be mounted.

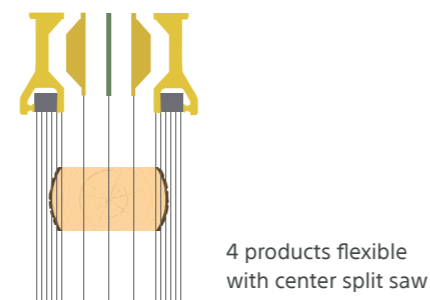

The cutting patterns are saved and can be selected via touch control panel from the operator control chair. The adjustment of the saw banks is possible from the operator control panel during normal operation. Sizing errors due to dirt contamination are excluded. Simple operation via touchpad. Encoders on all positioning drives of the saws enable a reliable, dimensionally accurate cutting.

The Vario SV4 is available for the sash gang types HDN, HDSN and GDZGE.

TECHNICAL DATA AND DETAILS

VARIO SV4



DEPENDING ON THE SAWS THE FOLLOWING SIZES CAN BE REALIZED:

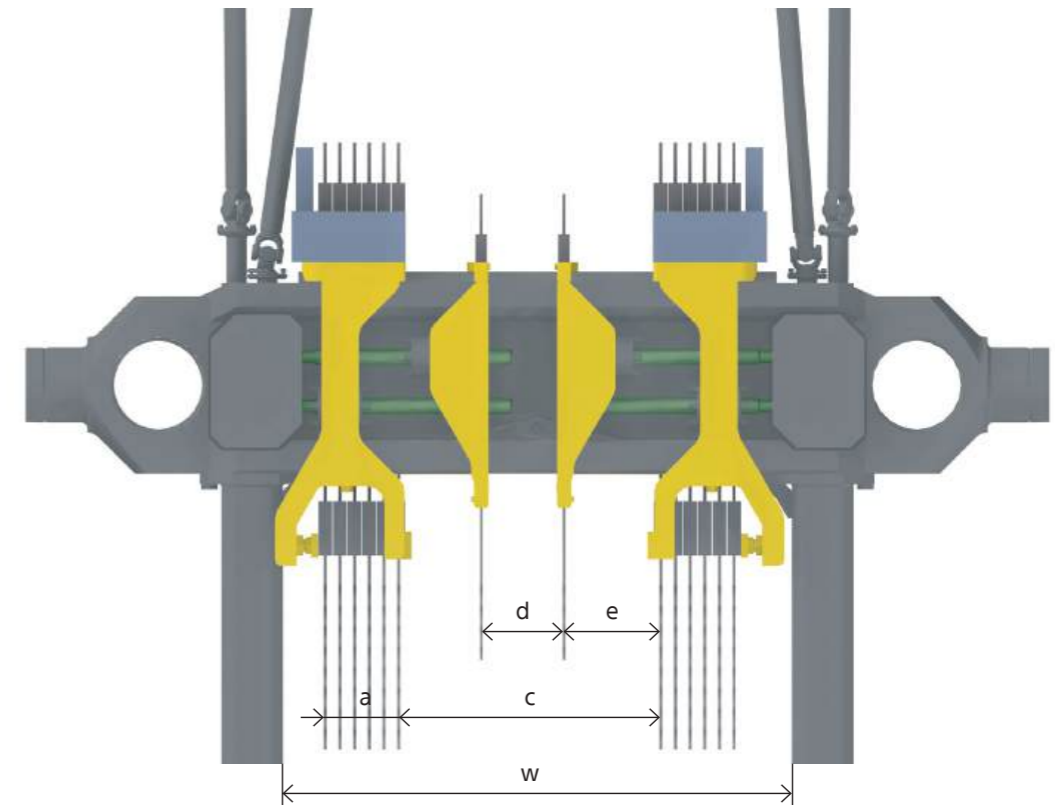

TECHNICAL DATA

			GDZGE 76	HDN / HDSN
Sash width	w	mm	755	740
Length of saw cluster	a	mm	110	115
Distance between the „saw clusters“*	max. c	mm	425	390
	min. c	mm	62	62
Distance between the „adjusting saws“	max. d	mm	380	350
	min. d	mm	18	18
Distance between the „saw cluster“ and the „adjusting saws“**	max. e	mm	190	175
	min. e	mm	18	18
Maximum center product width***	1x	mm	380	350
	2x	mm	180	170
	3x	mm	140	125

* 40 mm using a fix-mounted center split saw
 ** 23 mm with hydraulic side pressure unit
 *** in automatic mode due to in - out positioning moves less width!

The above listed sizes may vary when using side pressure units of other manufacturers, or other hangers, spacers.



USF SASH GANG FEED SYSTEM

Universal fast infeed carriage system, remote controlled



UNIVERSAL FAST INFEED CARRIAGE SYSTEM

For the feeding of the sash gang with logs and cants



FLAT DESIGN

The flat design of the USF provides stability, easy access and a low centre of gravity, whereby any tilting can be excluded. Logs may protrude beyond the carriage, allowing the processing of over-length logs. The modular construction allows adapting the USF to the client's specific requirements.

SEMI-AUTOMATIC REMOTE CONTROL SYSTEM

The carriage is remote controlled from an ergonomic operating chair. This allows a safe working environment according to current industrial safety regulations. The semi-automatic control system is relieving the operator and enables a constant high cutting performance.

UNIVERSAL FAST INFEED CARRIAGE SYSTEM

The infeed carriage for round logs, 2-sided cants and squared timber is suitable for all kind of sash gangs and different height of feed rollers. The loading of the carriage can be done from the left, from the right or from both sides.

The V-turner with special toothed chains in the main and auxiliary carriage enable a fast and simple rotation of round logs.



USF SASH GANG FEED SYSTEM

For highest requirements, for all kind of sash gangs



CLAMPING ARM

The ruggedly designed clamping arms are continuously adjustable in height. The operator can pick each log in the correct height and clamp it at the ideal position. The lateral adjustment of round logs and 2-sided cants is done by means of the clamping arm and the horizontally aligned special turning chains. The height of the arms is always set at the height of the previous log. This memory function is an important performance improvement for the sawing of sorted logs.

DRIVE

The USF has independent electric drives for common forward motion of main and auxiliary carriage with the speed of the sash gang feed speed, to catch-up with the previous log a fast forward speed of up to 60 m/min. and back in a defined loading position a fast return speed of up to 120 m/min. on a defined infeed position.

Main and auxiliary carriage receive power supply by flexible lateral cable chains, which can be installed on the right or on the left side.

OPTIONS

- Cant turner for turning of 2-sided cants of 180° or squared timber of 90° can be installed in the main and auxiliary carriage.
- Shifting V-log turner for main and auxiliary carriage allows to pre-align the log for the saw set-up center line even with asymmetric position of the saw set-up.
- Auxiliary clamping arm for fast centering of 2-sided cants or squared timber on the auxiliary carriage.
- Detection of log length enables a fully automatic positioning of the carriage during return.

TECHNICAL DATA AND DETAILS

USF



TECHNICAL DATA

Carriage width	mm	1800 + energy supply chain
Carriage width with option shifting V-log turner	mm	1900 + energy supply chain
Length main carriage	mm	3190
Length auxiliary carriage	mm	785
Track width	mm	980 - 1310 continuously adjustable
Height log infeed to top of carriage rails	mm	410 - 470 continuously adjustable
Rail height min.	mm	100
Log length LSH	m	from 2,3
Log length HDE	m	from 2,4
Log length HDN, HDSN, GDZ	m	from 2,5
Log length DWK SG	m	from 3,0
Log support width with V-log turner in horizontal position	mm	750
Side shifting distance with arms and turning chains	mm	+/- 125
Side shifting distance with option side shifting V-log turner	mm	+/- 80
Feed speed forward max.	m/min.	60
Feed speed reverse max.	m/min.	120
Drive motor main carriage Drive motor auxiliary carriage	kW	5,5 2,2
Weight main carriage basic configuration approx.	t	2,2
Weight auxiliary carriage basic configuration approx.	t	1,1
Memory function for height of clamping arms		The height positioning of the clamping arms is continuously selectable and is always the height of the previous log.

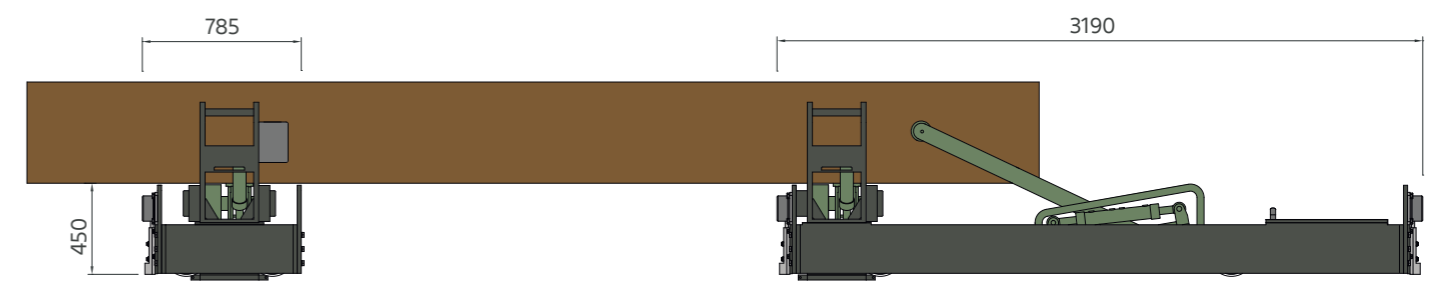
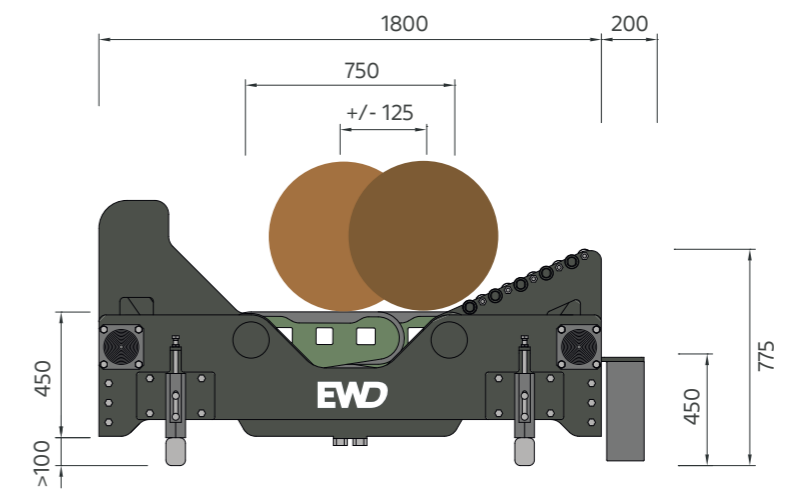

Dimensions (in mm)

ZE-F CENTERING AND INFEED TABLE

For round logs and two-sided cants, centered

The ZE-F centering and infeed table is designed for centered feeding of logs and cants to high-performance sash gang installations.

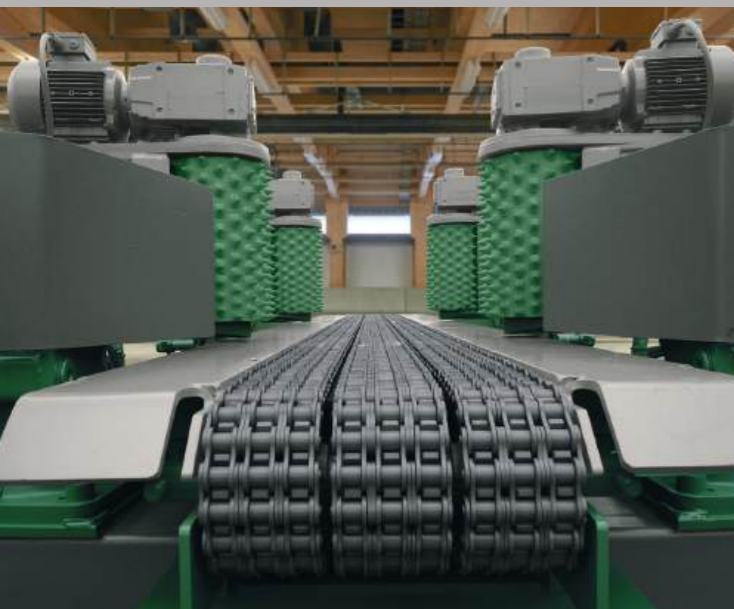
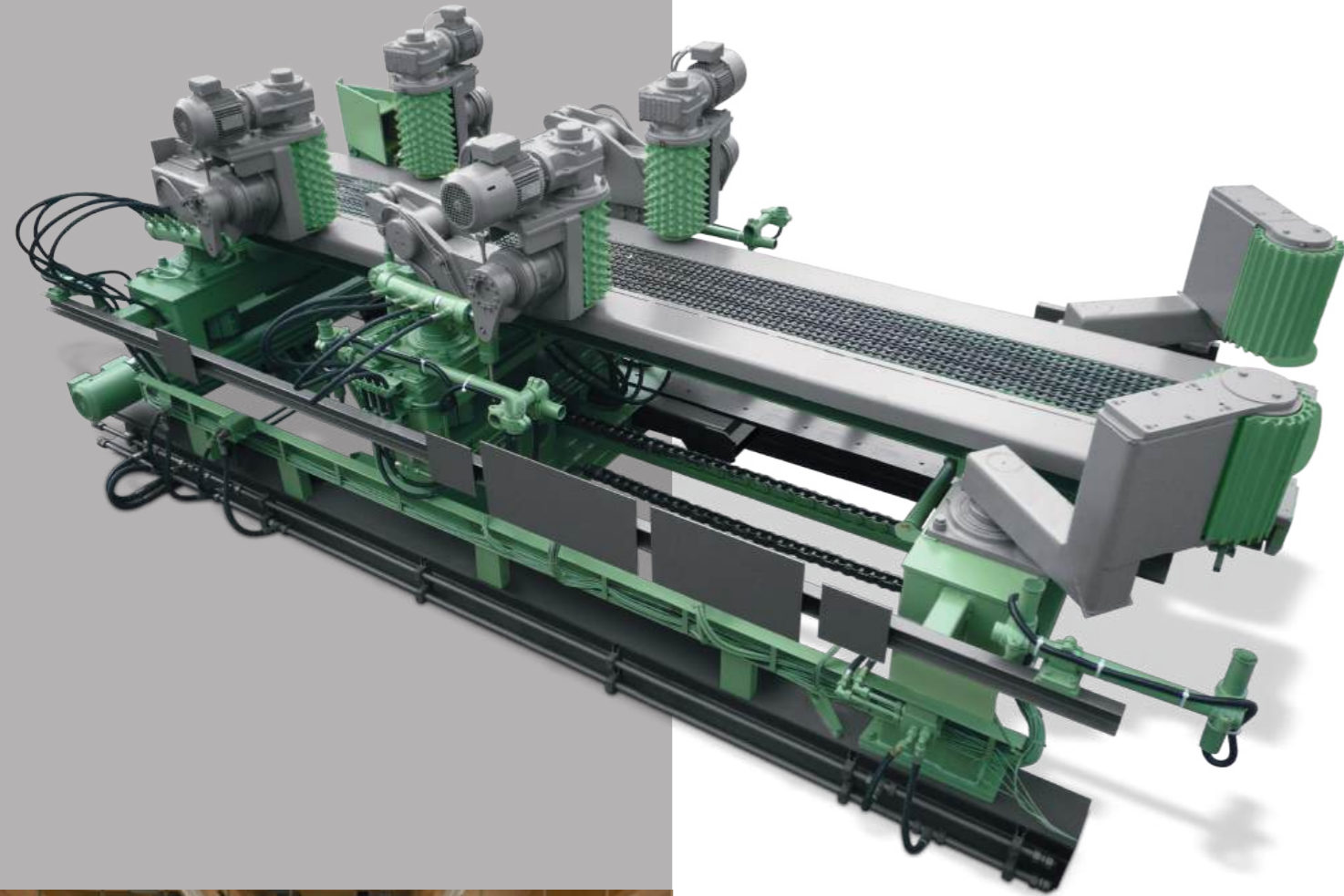

CONSTRUCTION

ZE-F Centering and infeed table



CONSTRUCTION AND FUNCTIONING

The ZE-F centering table is installed in front of a sash gang. It takes over the log from a log conveyor (measuring log conveyor) and transports it on a chain bed to the sash gang.

The chain bed generates the feed and fixes the position of the log during the feeding into the saw. An encoder at the drive of the chain bed ensures the correct guidance of the log. The automatic lubricating device ensures continuous lubrication.

The logs are centered by the two pairs of rotating rollers and turned in the sawing position by the operator. When the rotation is completed, the log is clamped so that it cannot move sideways or rotate while feeding it to the machine.

The feed speed is automatically adjusted to close the gap to the previous log.

The operator can use the second pair of spiked rollers for lateral alignment of the logs on the small end. The distance for the alignment is +/- 100 mm.

The centering roller pair positioned directly in front of the sash gang automatically centers the butt end of the log.

All swivel movements of the rollers are hydraulic. All feed drives are frequency controlled and automatically adapted to the feed of the sash gang.

WORKPLACE

The centering and infeed table is operated from the main control panel of the sash gang line. The ergonomic, comfortable operator cockpit is an integral part of the system.



ZE-F CENTERING AND INFEED TABLE

For round logs and two-sided cants, centered

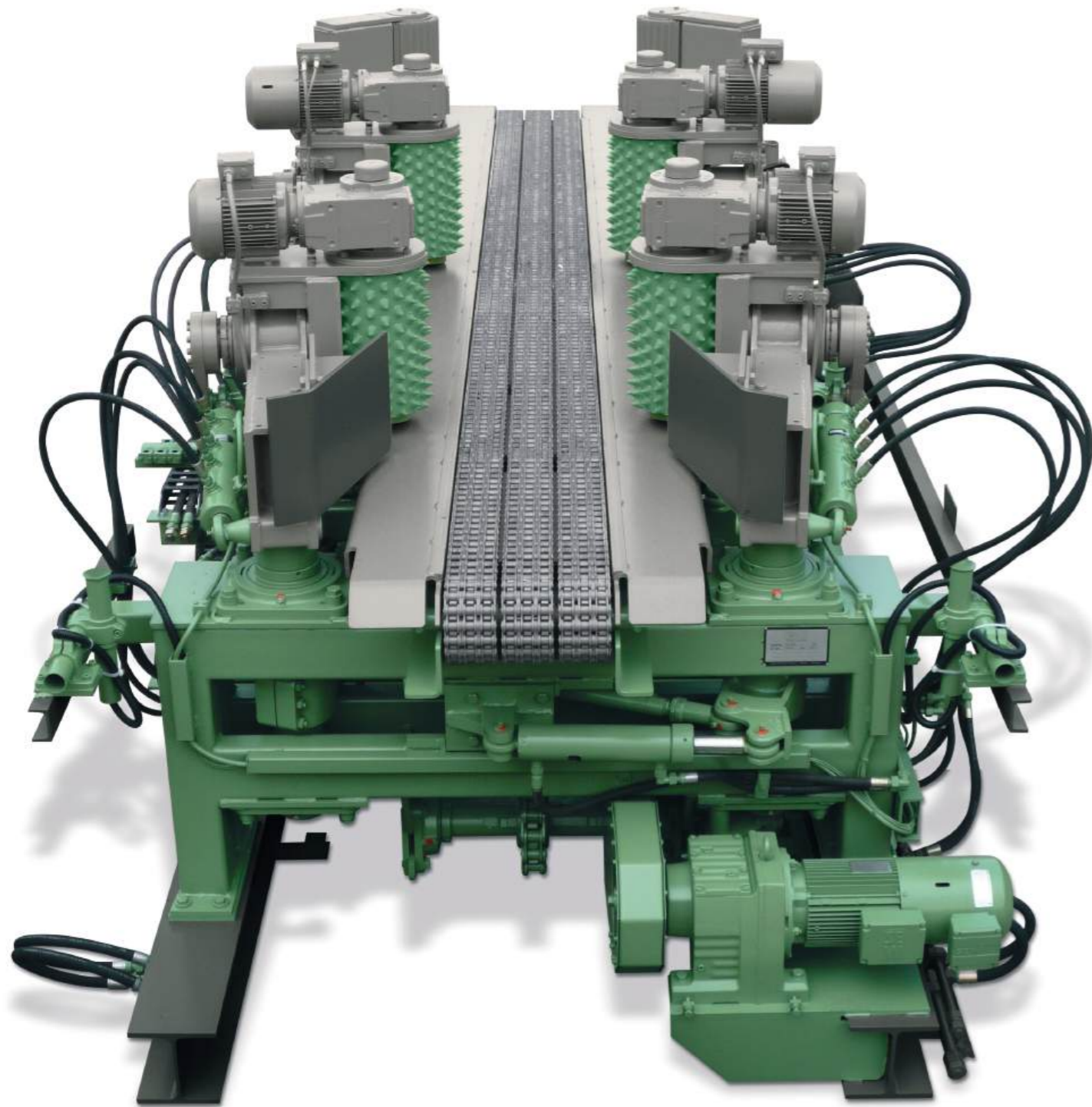

TECHNICAL DATA AND DETAILS

ZE-F

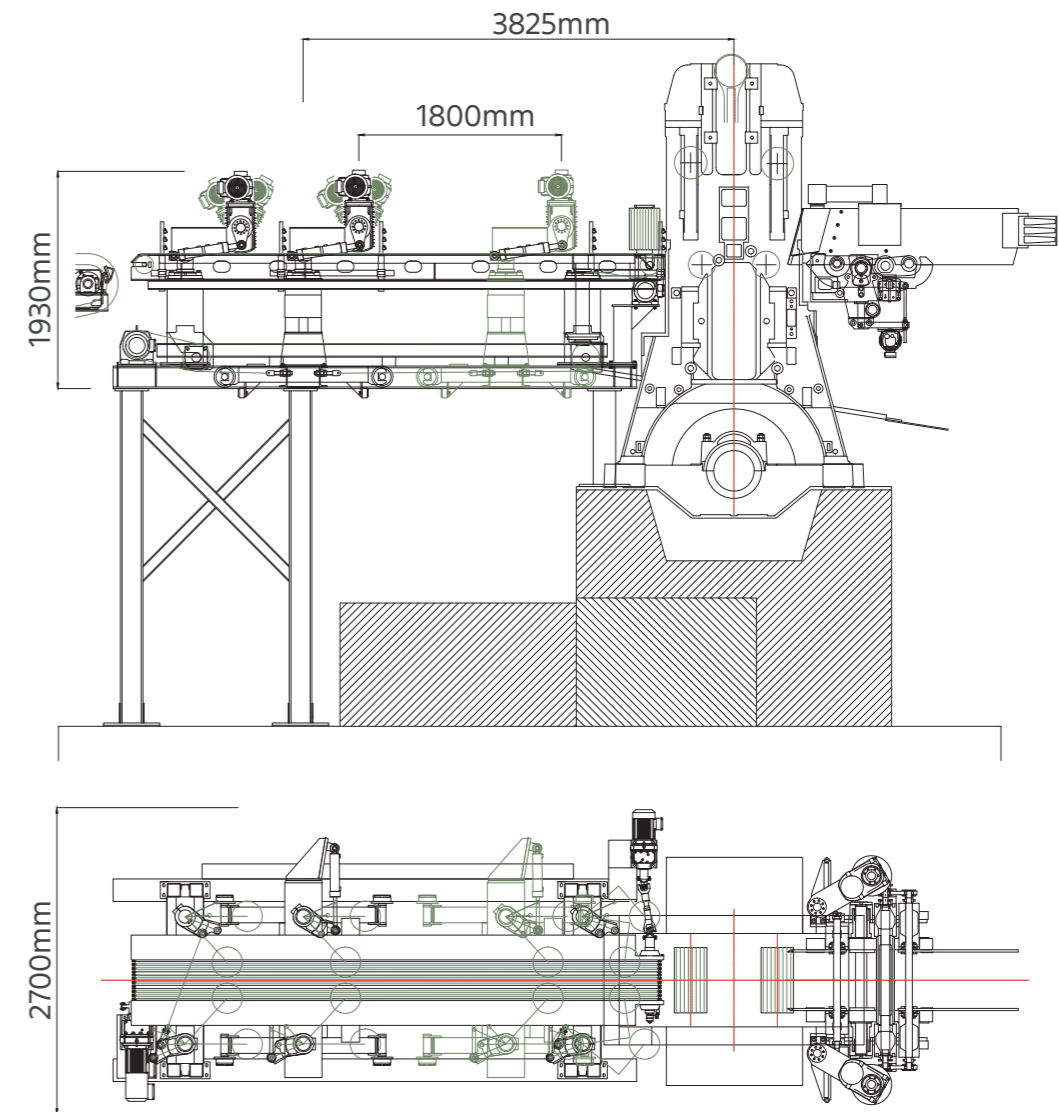

TECHNICAL DATA

Log/cant length min.	m	2,4 (1,8)
Log/cant length max.	m	6
Log diameter	mm	min. 70 - max. 700
Feed speed	m/min	20
	m/min	40 in case of closing a gap

Sawing mode thick end ahead

Adjustment		hydraulic
Centering width	mm	70 – 800
Pass through width	mm	50 – 800
Chain bed drive	kW	2,2
Pairs of rotating rollers, fix	pair	1
Drive per roller	kW	1,1
Pair of rotating rollers, moveable with lateral alignment function	pair	1
Drive per roller	mm	+/- 100
Drive per roller	kW	1,1
Drive pair of rotating rollers	kW	3,0
Pair of centering rollers, fix	pair	1, not driven

MAS BALANCING UNIT

Solution for installation of sash gangs on poor ground



ADVANTAGES OF THE BALANCING UNIT

- Elimination of disturbing vibrations on existing sash gang installations, protecting foundations and buildings in the sawmill and adjoining areas.
- Support to comply with environmental laws prohibiting vibrations exceeding a certain level.
- Foundations of new sash gangs are feasible even on poor ground.
- Use of the existing foundation, which can be in fact too small, in case of change of the sash gang.
- Also available with attachment kit for sash gangs of other suppliers.

TECHNICAL DETAILS

MAS Balancing unit

INERTIA FORCES OF FIRST ORDER

The inertia forces of first order can - depending on the application and requirements - be largely compensated by means of a one- or two-sided balancing unit. Here, masses rotating in opposite directions are used.

INERTIA FORCES OF SECOND ORDER

If, in special cases, the force differences between the top and bottom dead centre must also be compensated, a balancing unit of second order is available on request.

ATTACHMENT AND DRIVE

Due to the modular design, the drive can be varied and adapted to all sash gangs.

The unit is driven by the crank pins of the sash gang using a special clutch for connection.

The balancing unit is mounted on a concrete foundation (dimensions depending on the type of sash gang).

EWD

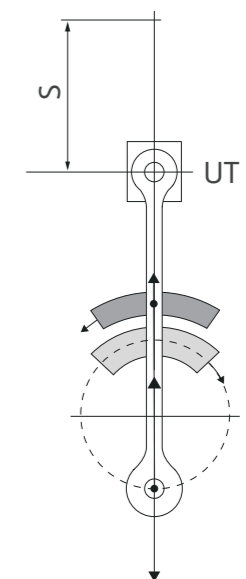
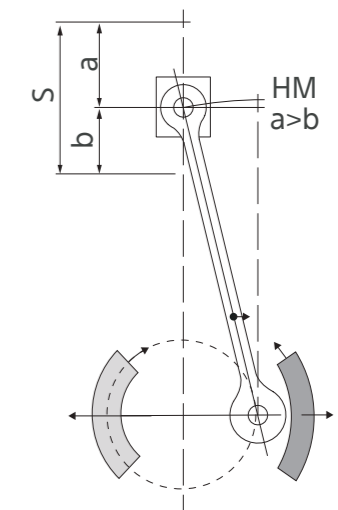
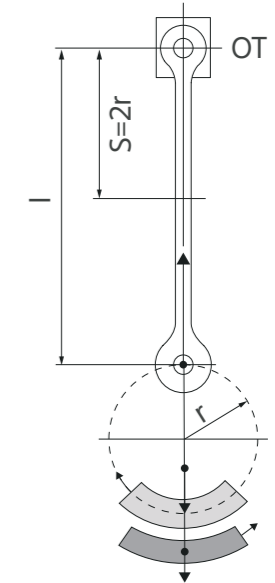



EWD

Esterer WD GmbH
Estererstraße 12
D - 84503 Altötting

T +49 8671 503 0
F +49 8671 503 386

Markwiesenstraße 40
D - 72770 Reutlingen

T +49 7121 5665 0
F +49 7121 5665 400

info@ewd.de