



EDGER OPTIMIZER TECHNOLOGY

EWD

Selection technology: EDGER OPTIMIZER TECHNOLOGY Plant system: COMBIMES

Contact | Account | LOG IN: User name | Password

DK90 / ASV Edger

BNK / ASV Edger / resaw combination

NQF Sideboard return

OPTION

Single-point laser from top / optionally bottom
 Full contour true shape scanning from top optionally, also top and bottom

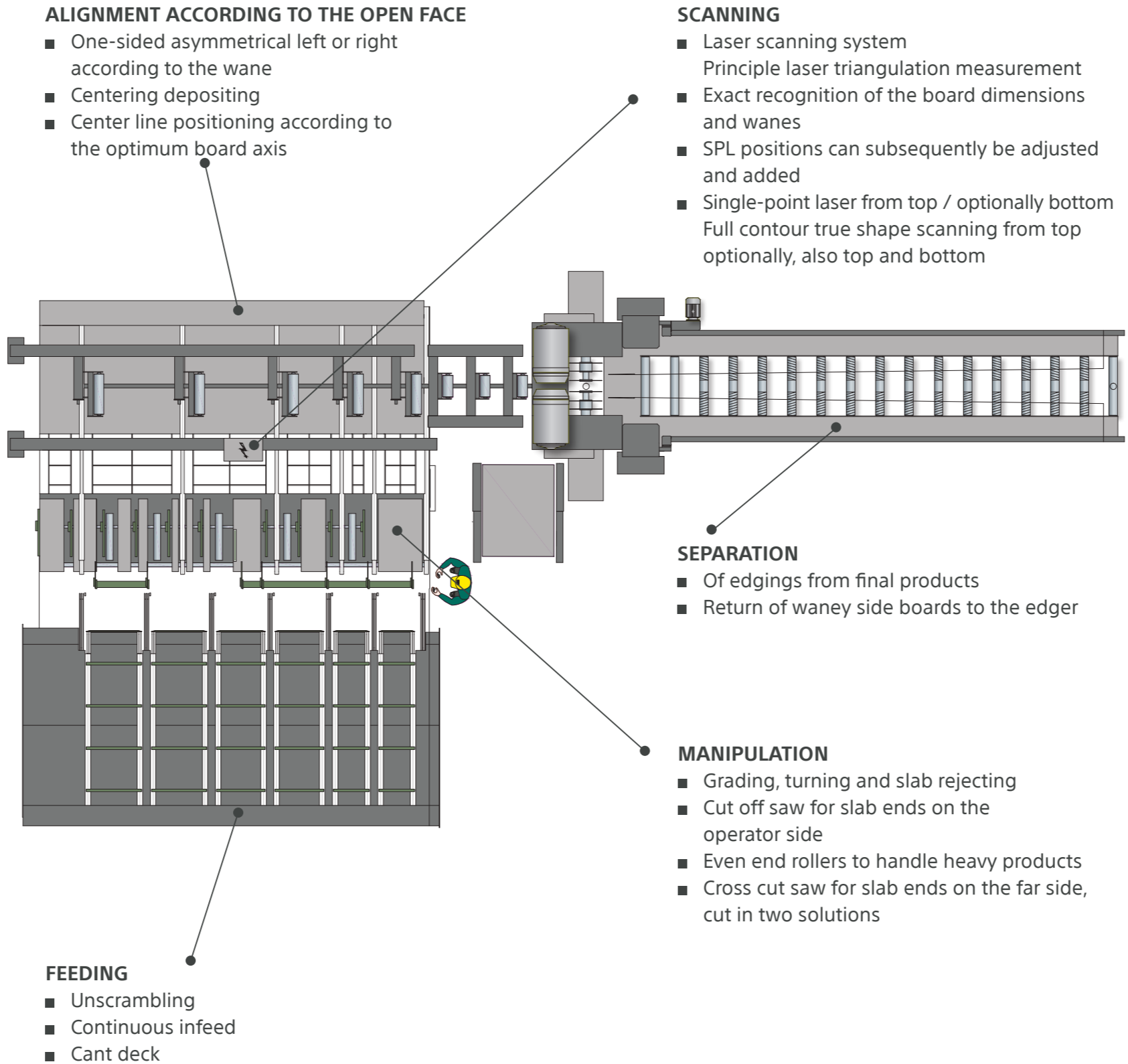

PF19 Chipper canter

BNK / VZW Circular resaw

FR15M Profiling unit

FR15H Profiling unit

EDGER OPTIMIZER TECHNOLOGY

DK 90 Manually fed edger



→ The perfect supplement to a main break down machine

Manually fed edging and resaw system for boards, flitches and small cants.

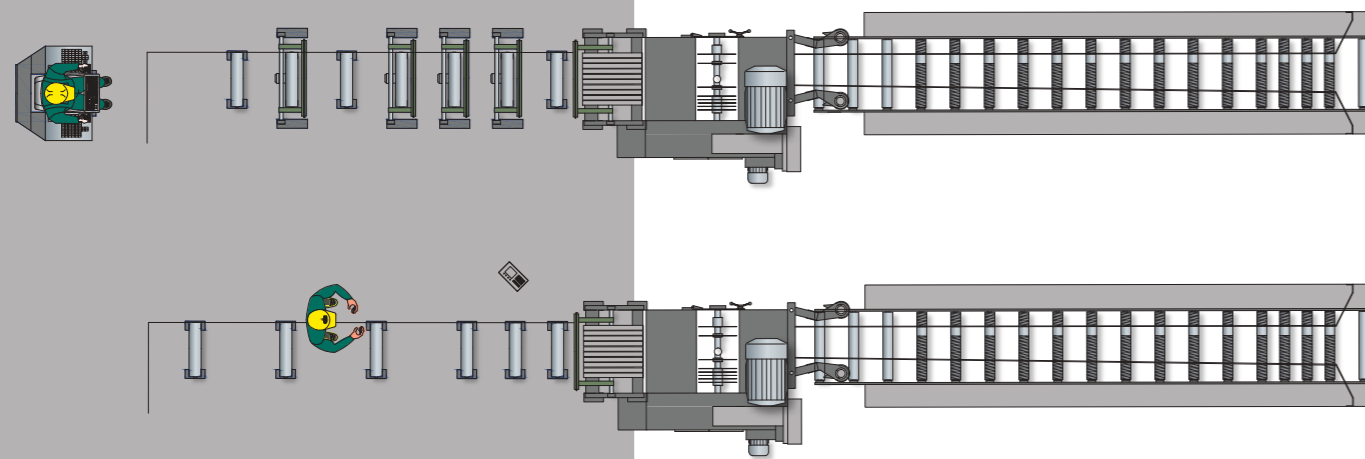

The manually fed edging and resaw unit DK 90 is a perfect supplement to main break down machines in small sawmills such as a sash gang or log band-mills.

In larger operations the DK 90 is used as a versatile side machine for varying tasks. The machine was refined in years of development and features reliable operation, also under tough conditions.

DK 90 MANUALLY FED EDGER

Technical data

TECHNICAL DATA

Board length min.	m	1.0
Board width unedged	mm	80-700
Board thickness	mm	15-120
(Special design)	mm	160
Operation on the machine		

TECHNICAL DATA DK 90 MANUALLY FED

Machine opening	mm	950
Feed speed max.	m/min	100
saw arbor drive	kW	1 x 37-132
Special design		
direct drive	kW	160
Weight including drive motor approx.	t	5.0



SAW SET DISTANCES DK 90 L

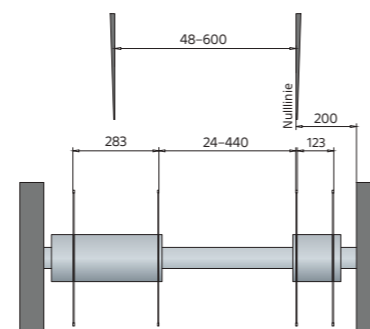

DK 90 TL

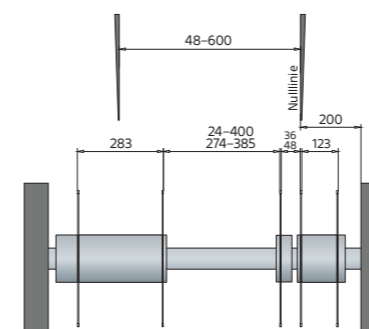

DK 90 T2L

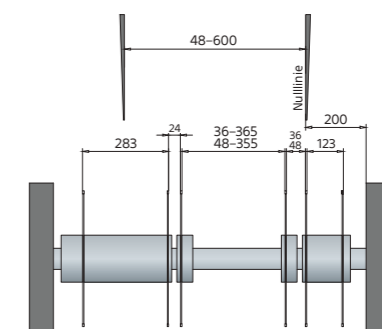

- Boards
- Flitches
- Cants

The comprehensive range of EWD optimizer scores with the world's widest range of applications and meets the requirements of the modern sawmill industry in all aspects.

The edger optimizer system Combimes provides steady performance class of up to 24 boards per minute. Its robust design ensures superior production and yield figures, even under tough conditions.

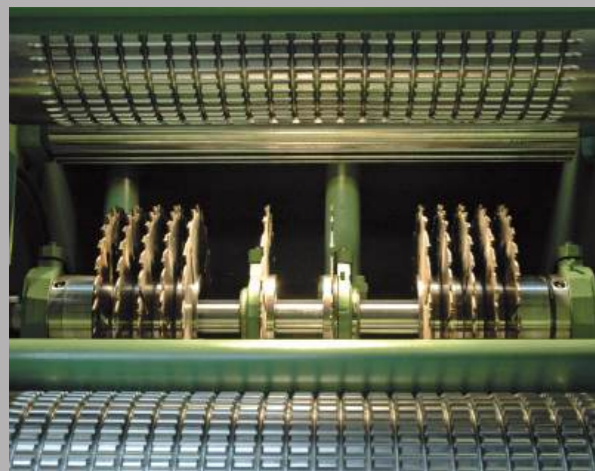

The Combimes can be used for a wide variety of production tasks thanks to different models of edger and combination edger/resaw units available.

PROCESS

Depending on the mechanical design, the operator can turn the products at his workplace, trim and enter quality information or lumber species. The scanning takes place in the integrated cross transport with 2 dogs, with which the products are then aligned and transferred directly to the longitudinal transport in the saw.

BOARD MANIPULATION

Before handing over to the infeed table, the products can be turned or rejected with a hydraulically operated device, which at the same time serves as a slab flap. At the partially automated trimming station, the boards are then usually cut to the final length on the top end with the integrated O-saw.

Further possibilities:

- End slab saw at approx. 3 m with ejection of the remaining piece within the operation zone
- Separating and end slab saw for board separation into 2 pieces or discharge of remaining pieces
- Lifiable and lowerable driven aligning rollers for manipulating heavy products or for moving a separated board

For higher performance requirements, a separate board manipulation with automatic functions can be installed in front of a Combimes.

This board manipulation is remote-controlled by the operator from a cabin.

For reasons of capacity, a faulty slab cutting to approximate length is usually made only if necessary.

THE MECHANIC

The chains of the measuring and depositing cross conveyor are controlled independently with frequency converters for the defined transport of the product with dogs and positioned.

The transport speed is selected depending on the product thickness.

Reflective photo eyes installed in the feed table determine the approximate board length. Based on the result the required active chain runs are selected.

The feed speed of the infeed chain adjusts itself automatically depending on the lumber thickness and the number of saws cutting. The speed may be limited or e.g. be reduced for winter operation.

All skewing and lifting movements of the infeed table are hydraulically actuated.

WANE-PARALLEL SAWING

With appropriate mechanisation with a product guide, thanks to the free alignment possibilities of a Combimes system, fibre-parallel value wood cuts can be made in 2 passes along the outer contour with residual piece in the middle.

ELECTRONICS

Scan data are processed by an industrial PC, together with an eventual operator quality or lumber species input. Using the selected edging program and depending on length, thickness and width of the lumber, the desired products are sawn. A wane allowance for products can be entered as percent or absolute value, separately for the left and right side. Different values can be set for different active products. Value optimization generates the product with the highest value (price). The position values of the saws calculated by the optimization are transferred to a ProfiNet connected PLC, controlling sequence functions and hydraulic positioning of the saws, as well as the safety technology according to current requirements by using a safety PLC. The system states are displayed graphically. PC and PLC are equipped with a remote maintenance access via Internet.



Use your phone or tablet to scan this QR Code and see the Combimes in action.

THE SCANNING

The cross-sections of the products are scanned to determine the top surface by means of laser triangulation from top. Depending on the design, products with a thickness of up to 120 mm or 225 mm can be scanned.

When using single lasers, the distance and number of scan points can be selected, from 13 lasers for 6 m workpiece length in the standard version up to 25 lasers.

Alternatively, a laser scanner is available from bottom, eliminating the need to turn the products. Alternatively, the system can be equipped with a full contour scanning system for special requirements.



Alignment right



Alignment middle



Alignment left



→ For sawing heights
of 17–120mm

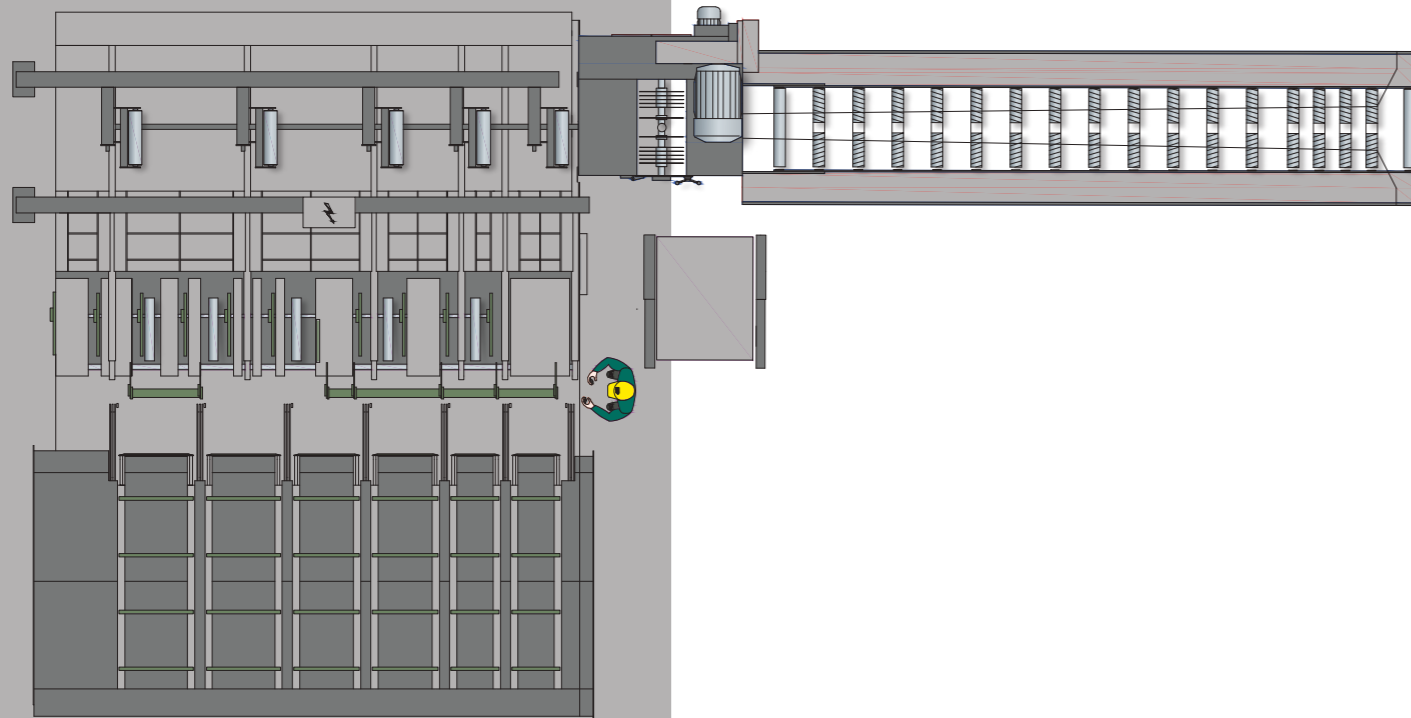

TECHNICAL DATA

Capacity in edging mode at board length 4.1 m
and board width 200mm max. pieces/min 18

Board length	m	1.0–6.0
Board width unedged	mm	80–700
Board thickness	mm	17–120
Special design	mm	160
Partially automated	operation on the machine	

TECHNICAL DATA DK90

Feed speed max.	m/min	20–160
Saw arbors drive (Special design direct drive)	kW	1 x 37–132 kW 160
Weight including drive motor approx.	t	5.0



SAW SET DISTANCES

DK 90 T2L2

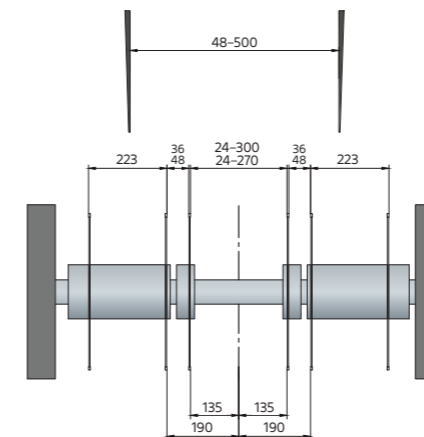

DK 90 TL2

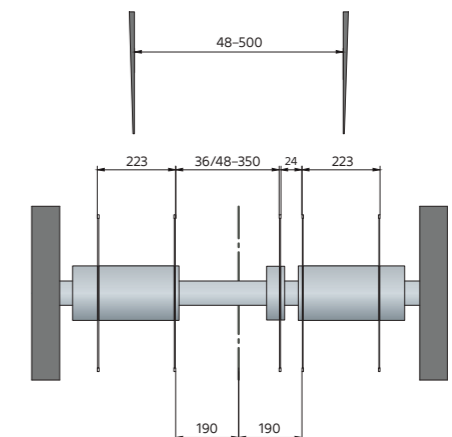

→ For sawing heights
of 17–120mm

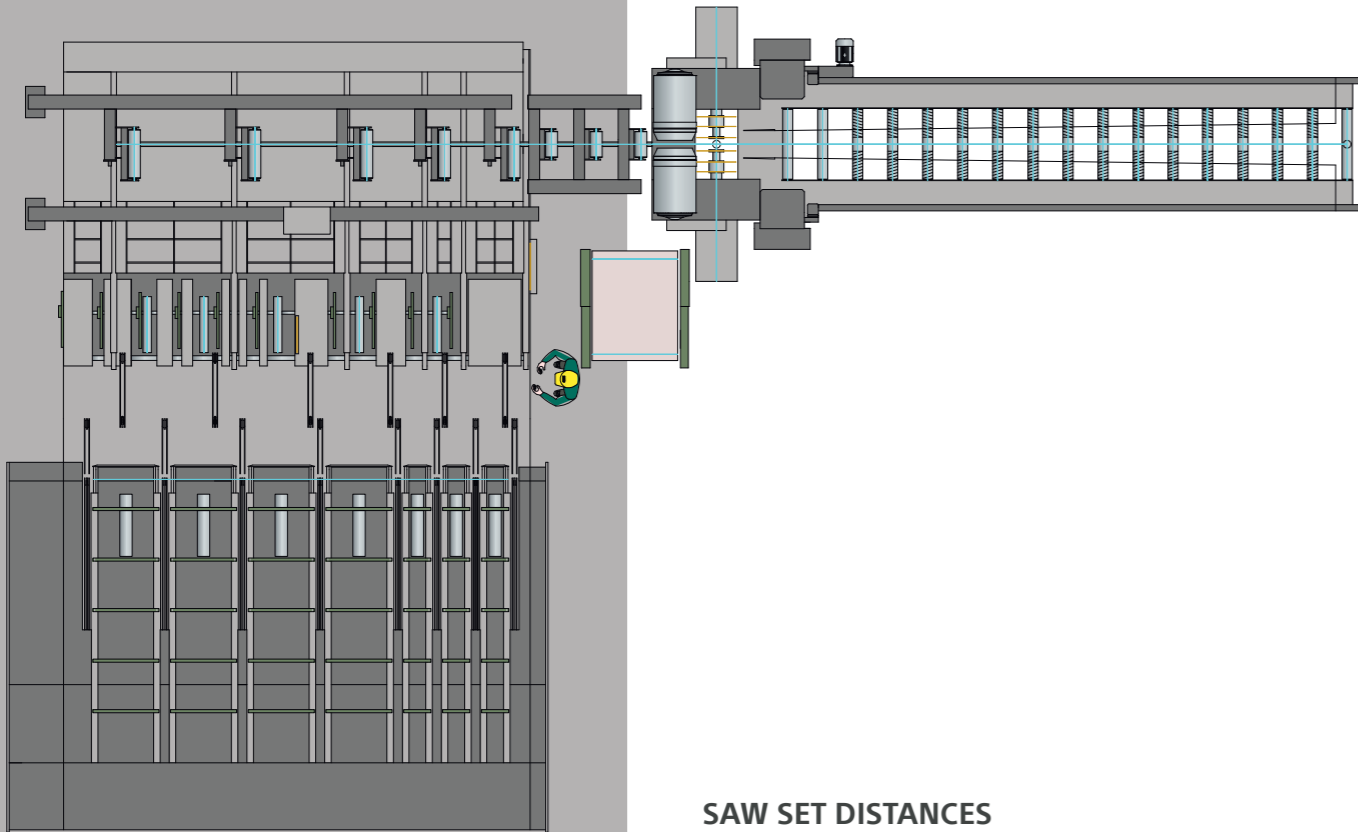

TECHNICAL DATA

Capacity in edging mode at board length 4.1 m
and board width 200mm max. pieces/min 22
Board length m 1.2–6.0
Board width unedged mm 80–700
Board thickness mm 17–120
Partially automated operation on
the machine

TECHNICAL DATA BKO

Feed speed max. m/min 20–210
Saw arbors drive kW 2 x 75–132
Weight including
drive motors approx. t 5.8



SAW SET DISTANCES

BKO 3

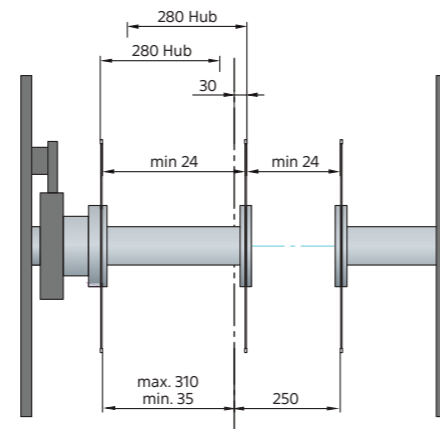

BKO 4

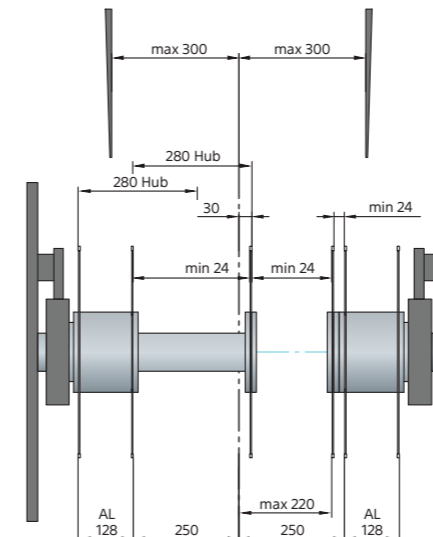

BKO 6

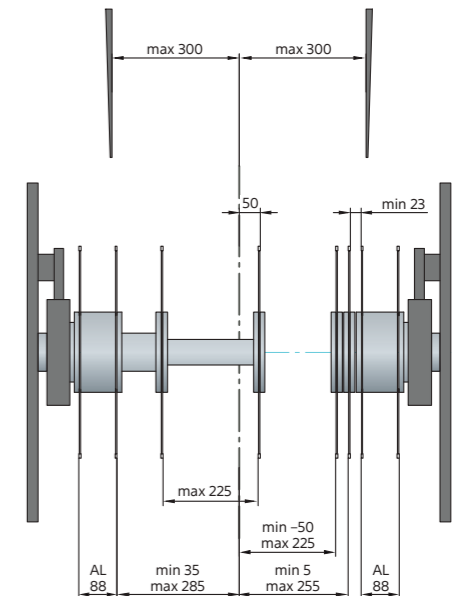

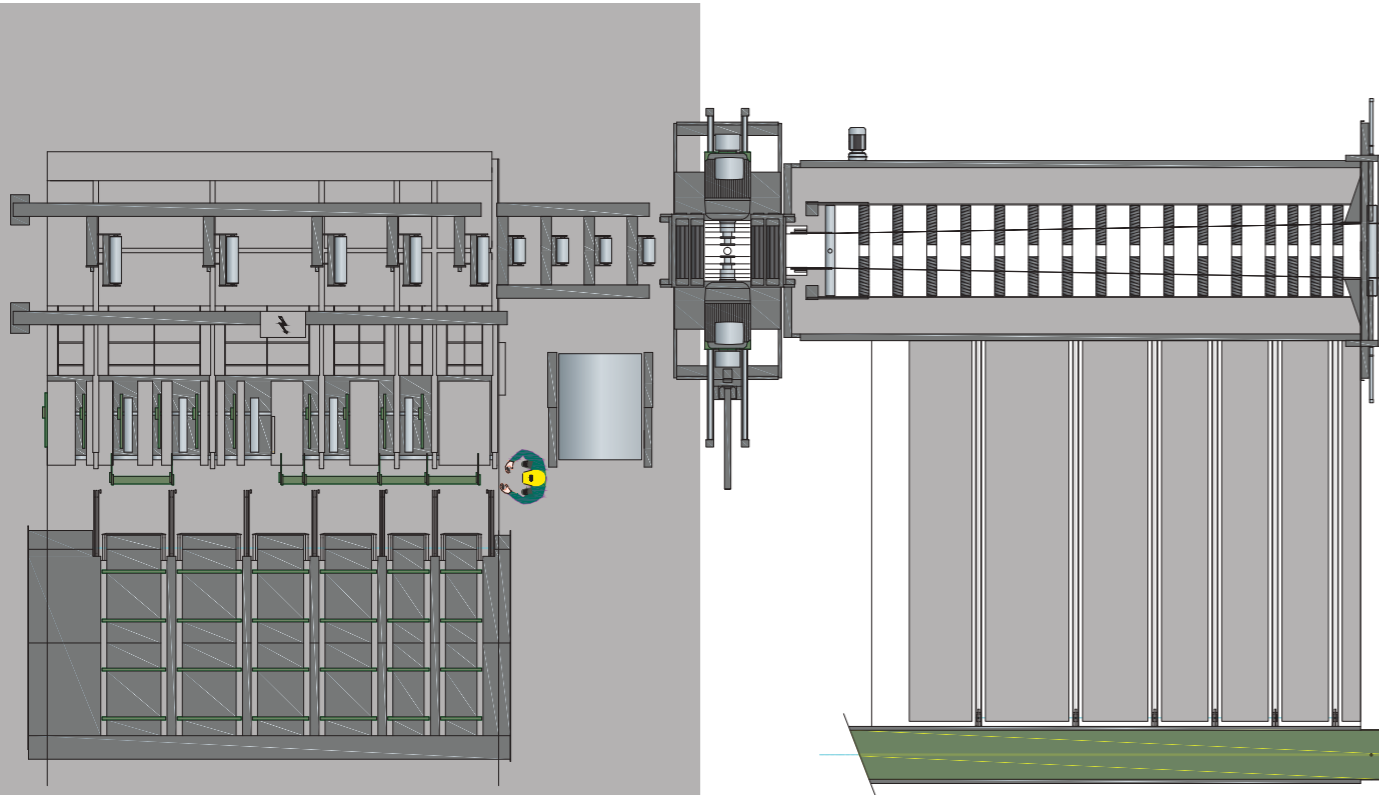

TECHNICAL DATA

Capacity in edging mode at board length 4.1 m and board width 200mm max.	pieces/min	20
Board length	m	1.2-6.0
Board width unedged	mm	80-700
Board thickness	mm	17-225
Partially automated	operation on the machine	

TECHNICAL DATA BNK

Feed speed max.	m/min	20-180
Saw blade diameter	mm	450-700
Sawing height \varnothing 450 mm	mm	100
Special design		
Maximum Sawing height	mm	160
possible board length minimum	m	1.0
Saw arbors drive	kW	2 x 75-132
(at 2.400 rpm of the saw arbors)		
Weight including drive motors approx.	t	12

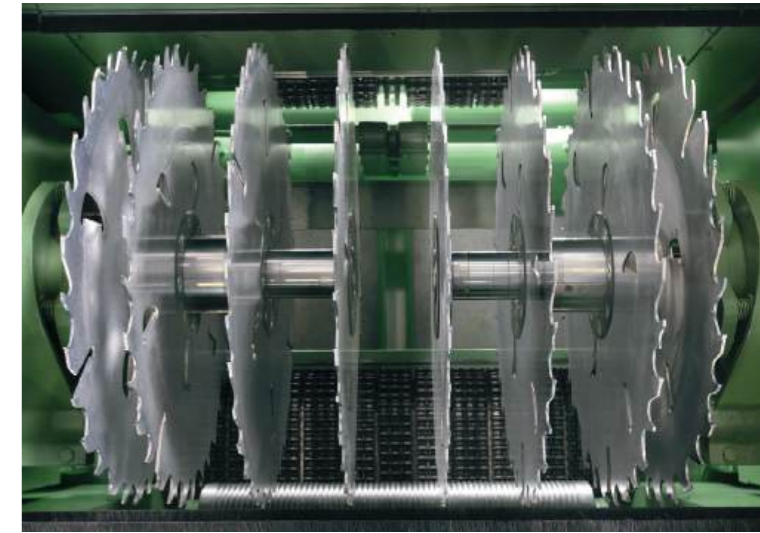

SAW SET DISTANCES BNK 6

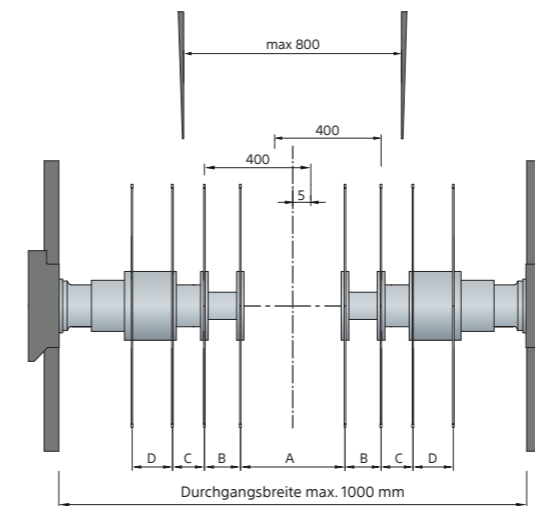

A = 18 - 730 mm
 B = 18 - 205 mm
 C = 18 - 143 mm
 D = Aufspannlänge 115



→ Maximum value yield

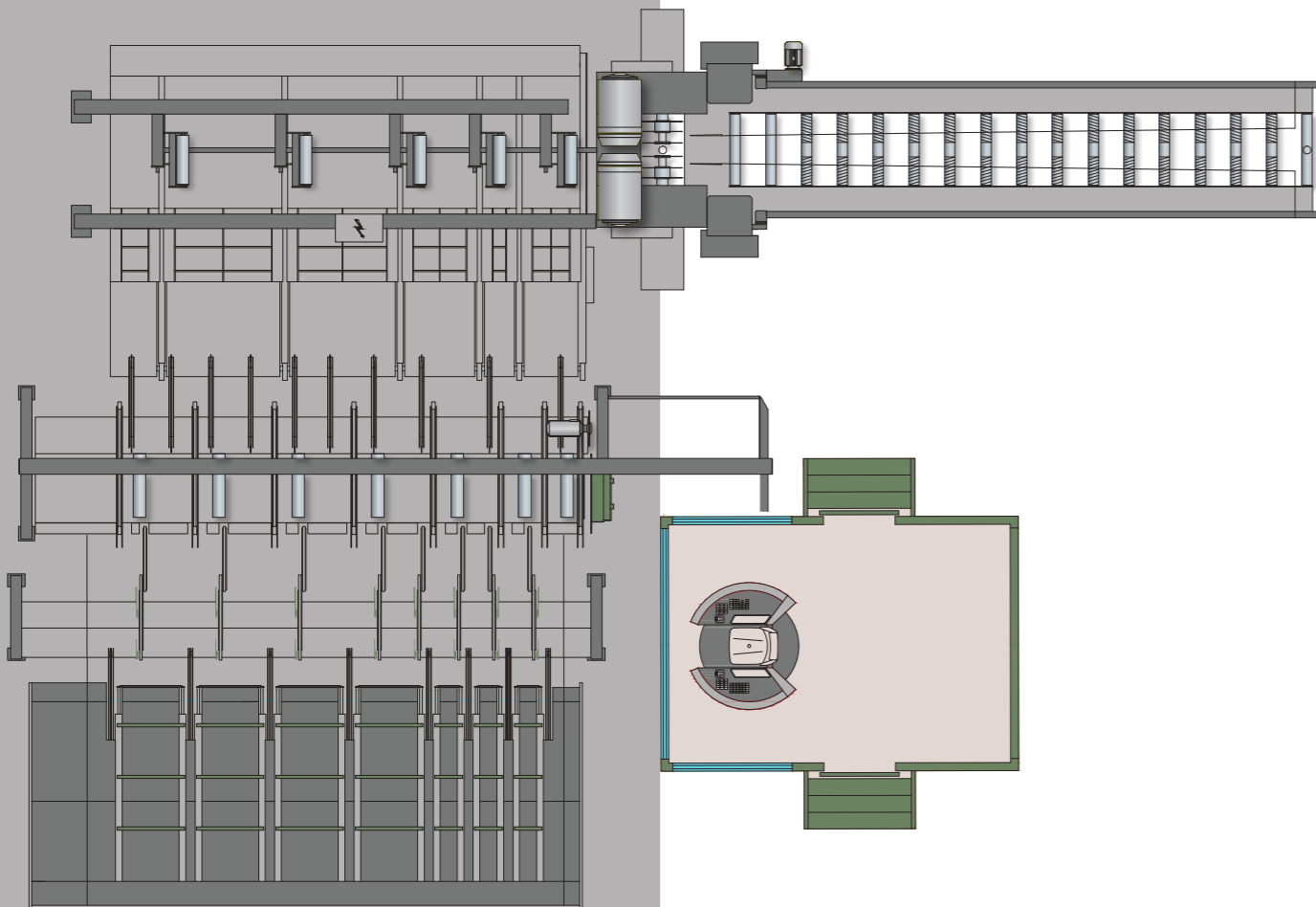

TECHNICAL DATA

Capacity in edging mode at board length 4.1 m and board width 200mm max. pieces/min 24
 Board length m 1.2-6.0
 Board width unedged mm 80-700
 Board thickness mm 17-120
 Automated operation from a cabin

TECHNICAL DATA BNK

Feed speed max. m/min 20-210
 Saw arbors drive kW 2 x 75-132
 Weight including drive motors approx. t 5.8

BOARD UNSCRAMBLING

Boards from the transfer conveyor are separated by an S-shaped cross conveyor with bars. Hydraulically operated flippers can kick out the leading board in case of a double occupancy of the bars. A faster running cross conveyor pulls the board from the bars after the unscrambling process.

GRADING AND BOARD HANDLING STATION

At this position, the operator can influence the further processing of a board, with the following possibilities:

- Input of a quality/grade information
- Decision for a specific board alignment
- Turning of a board to grade the 2nd face
- Input of a trim back decision
- Activation of the drop-out gate for reject pieces
- Reverse and clear conveyors of astray board(s)

BOARD TRIMMING

A 0-line trim saw and driven feed rollers allow to trim back the fish tail end of a board by 0,5 -1,5 m upon operator command to avoid further problems because of the slab end.

THE OPERATION

The control of the complete system is done from an control cabin. An ergonomic, comfortable operator chair is an integral part of this system.



→ An innovation within the
EWD Edger optimizer program

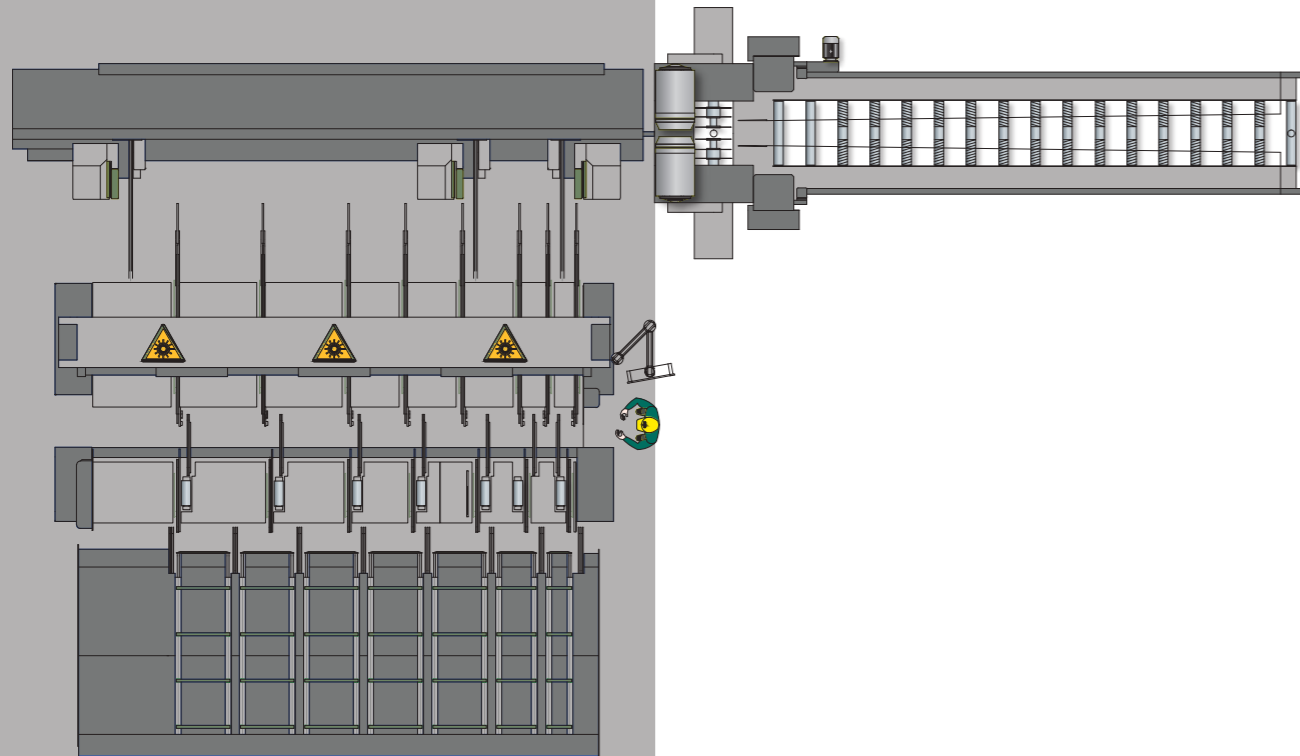

→ Trimming and Edging System



Trimming and Edging System for boards, flitches and cants. Innovation and revolution for small to medium sized sawmills.

UNSCRAMBLING AND MANIPULATION

After the unscrambling process the product is transported to the grading and board manipulation area on a sharp chain without dogs.

For the infeed system, no flushline is required.

The operator has the following possibilities:

- Turning of a board to grade the 2nd face. Activation of the drop-out gate for reject pieces. Optional end slab pre-cutting.
- Return transport to the unscrambler.

No further interventions are necessary.

The modern optimization and user software eWood supports the operator.



BOARD MEASUREMENT

Board, flitch or cant profiles are scanned in cross transfer by a continuous optical measuring system.

Slabs or parts of slabs will be recognized by the board measurement and can therefore be cut off.

An integration of an image processing system for grade scanning is possible.

The top measurement automatically detects thick-ness, length and width of the wane. The PC full optimization selects the optimum cutting pattern according to this data.

Automatically positioned saw carriage units take over the product during the transfer and perform a crosscut (trimmer function), rectangular to the calculated board edge and to the final length.

After positioning on the CET Infeed Table according to the optimization result, the product is sawn in the edger.

Different combinations of machines within the system with edgers and resaw circular saws, chipping and profiling units are possible.

FUNCTION PARTIAL BOARD/SADDLE BOARD

The board is separated in length on the basis of the measured data in such a way that optimum value is created. Both boards are transferred to the infeed table without any loss of time.

ONLINE SYSTEM

An online system without singulator and operator is possible for certain scopes of application.

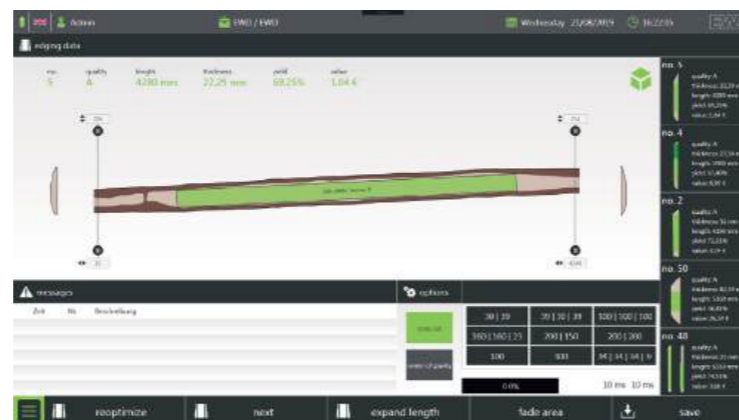

Use your phone or tablet to scan this QR Code and see the Combimes in action.

TECHNICAL DATA

Capacity in edging mode at board length 4.1 m and board width 200mm at depending on the version max.

Board length	m	1.2-6.0
Board width unedged	mm	80-700
Board thickness	mm	17-120
Partially automated	operation on the machine	
	pieces/min	18 / 24

TECHNICAL DATA BKO

Feed speed max.	m/min	20-210
Saw arbors drive	kW	2 x 75-132
Weight including drive motors approx.	t	5.8

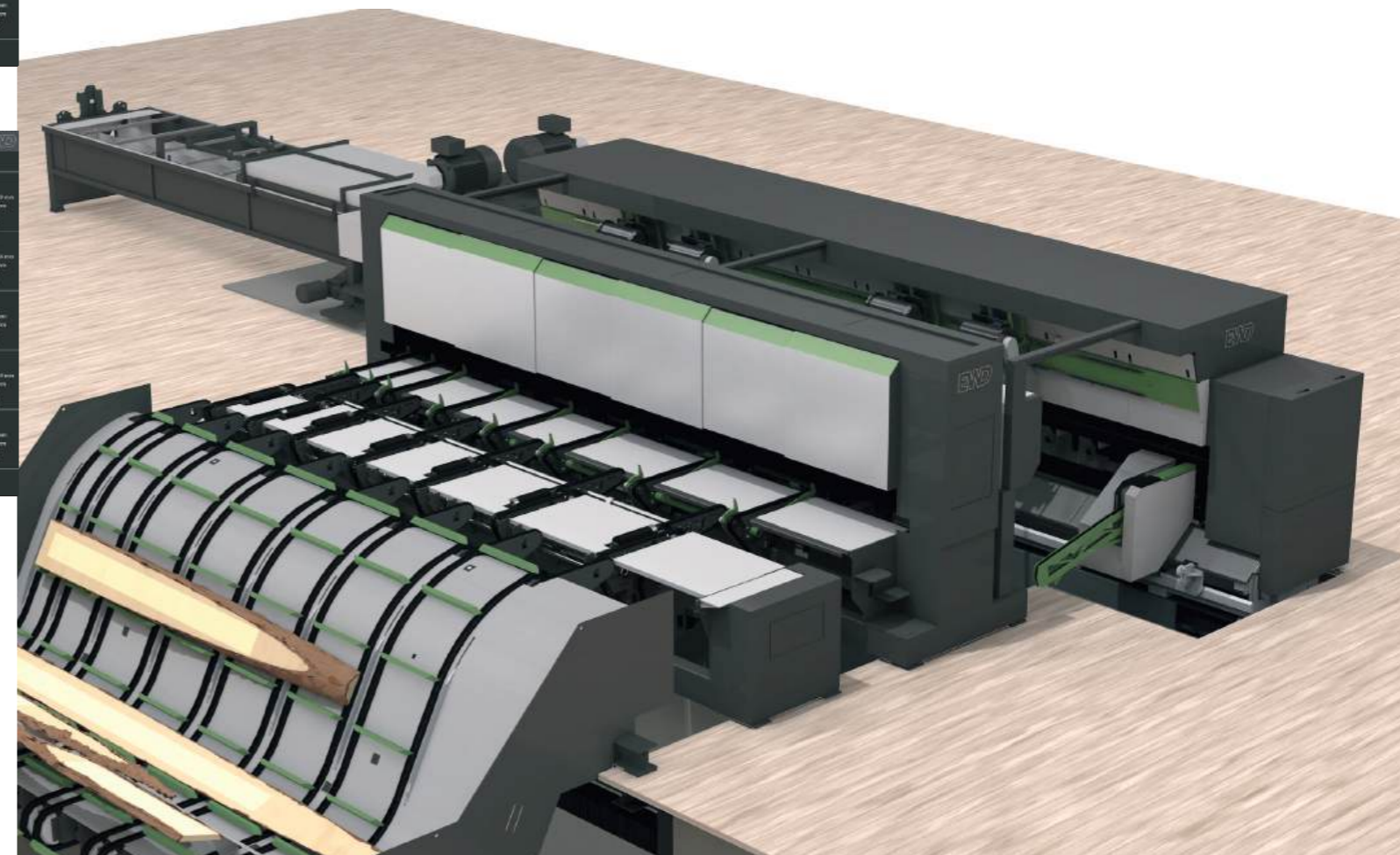

→ An innovation within the EWD Edger optimizer program

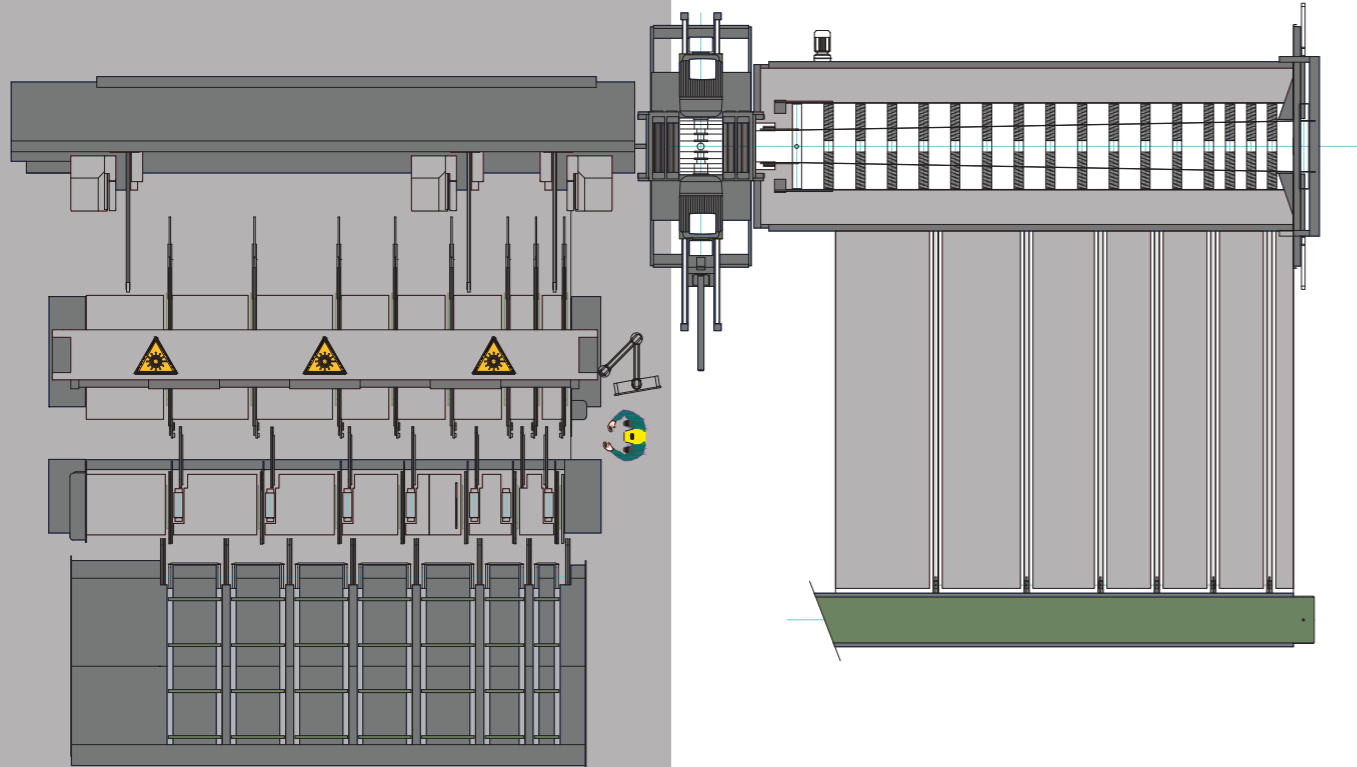

TECHNICAL DATA

Capacity in edging mode at board length 4.1 m and board width 200mm at depending on the version max.

	pieces/min	16 / 18
Board length	m	1.2-6.0
Board width unedged	mm	80-700
Board thickness	mm	17-225
Partially automated	operation on the machine	

TECHNICAL DATA BNK

Feed speed max.	m/min	20-180
Saw blade diameter	mm	450-700
Sawing height ø 450 mm	mm	100
Special design		
Maximum Sawing height	mm	160
possible bord lenght minimum m		1,0
Saw arbors drive	kW	2 x 75-132
(at 2.400 rpm of the saw arbors)		
Weight including drive motors approx.	t	12

SAW SET DISTANCES BNK 6

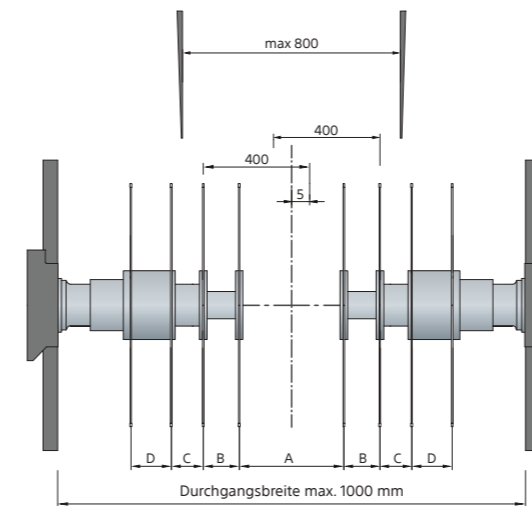

- A = 18 - 730 mm
- B = 18 - 205 mm
- C = 18 - 143 mm
- D = Aufspannlänge 115



→ For efficient and economically optimized trimming

OptiTrimm means optimized trimming: recovery or value-oriented production of defined finished lengths according to customer specifications. Several saws, combined with the servo-hydraulic positioning end stop, cut the board length as commanded by the scanning/optimization system from the edged board, including customer specific overlength.

Slab ends of the edged board as well as reject boards are cross-cut with all saws applicable, allowing to drop the short pieces directly to the waste handling system.

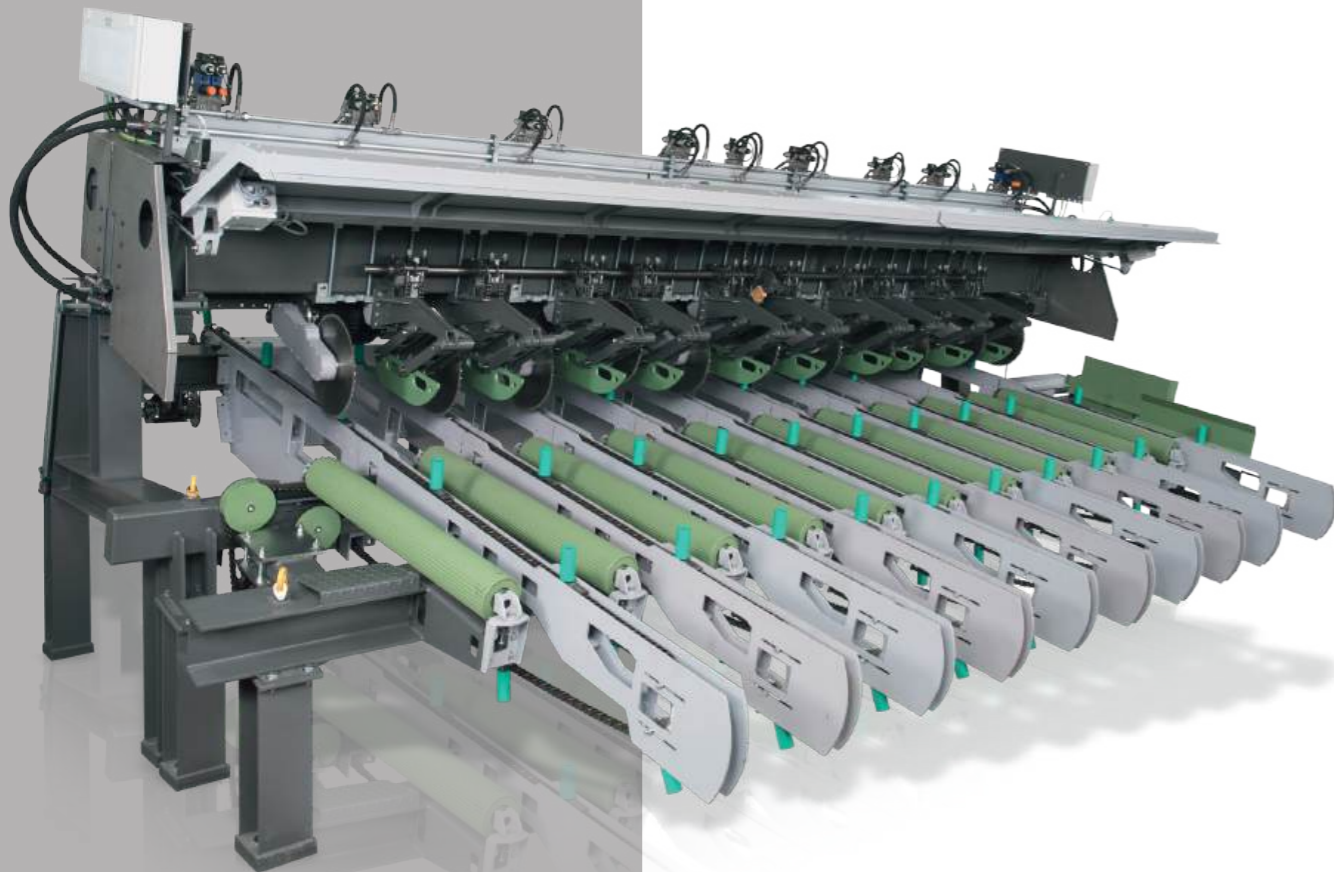

The cross-cut saws are driven by an electric motor. The force is transferred to the saw blade by means of poly-V belts.

The belts are installed in fully closed housings, which can easily be opened for maintenance purposes.

During operation the machine housing is closed. A connection to a dust extraction system is provided.

For tool change and maintenance, front and back covers are opened hydraulically for easy access.

The saw blades can be locked for tool change.

TECHNICAL DATA

Motor size	kW	5.5 each 2 saws
Trimm length module	mm	500
Adjustable stop	piece	1
Adjustable 0-saw for length increments other than 0,5 m		on demand
Board thickness max.	mm	60
Bigger board thickness		upon request
Board width min.	mm	80
Board width max.	mm	320
Wood species		softwoods, hardwood

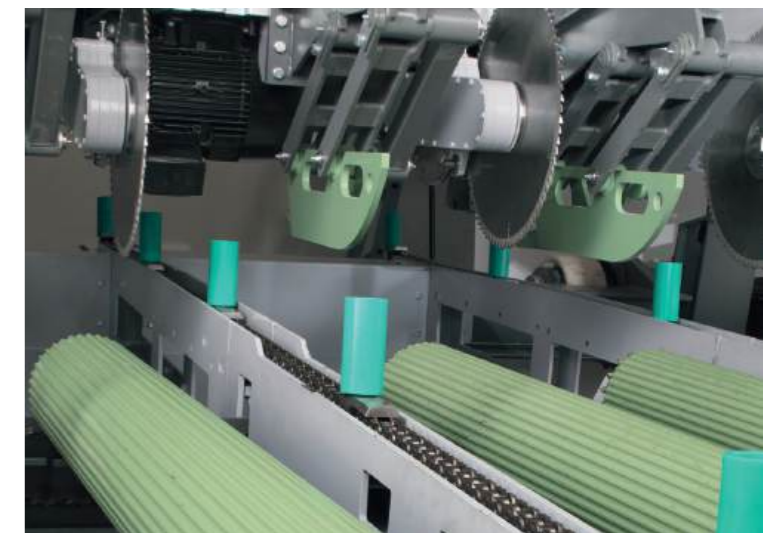

EDGER OPTIMIZER TECHNOLOGY

FR15 H Profiling unit

→ Profiling with heads installed on horizontal motor shafts, for variable position and width of the side board

The profiling unit FR15 H does profiling of 1 side-board on either side of a cant, with variable width and position. In front of the FR15 H unit is typically a chipper canter unit PF19 installed.

Asymmetric profiling solutions in board width and thickness as well as one-sided board solutions (left/right side) are also possible.

The horizontal and vertical positioning of profiling heads is done by servo-hydraulic networks.

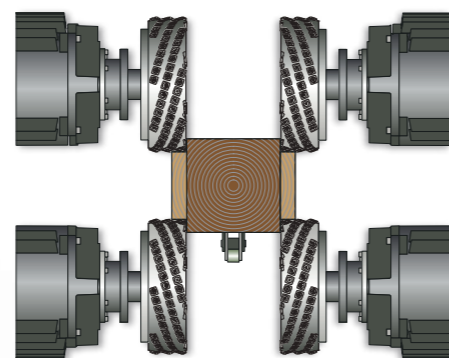

TECHNICAL DATA

profil board width	mm	70-225
Board width unedged	mm	70-225
Board length min.	m	2.4
Feed speed max.	m/min	150
Saw arbors drive	kw	4x50-65
Weight with 4 drive motors approx.	t	13.0

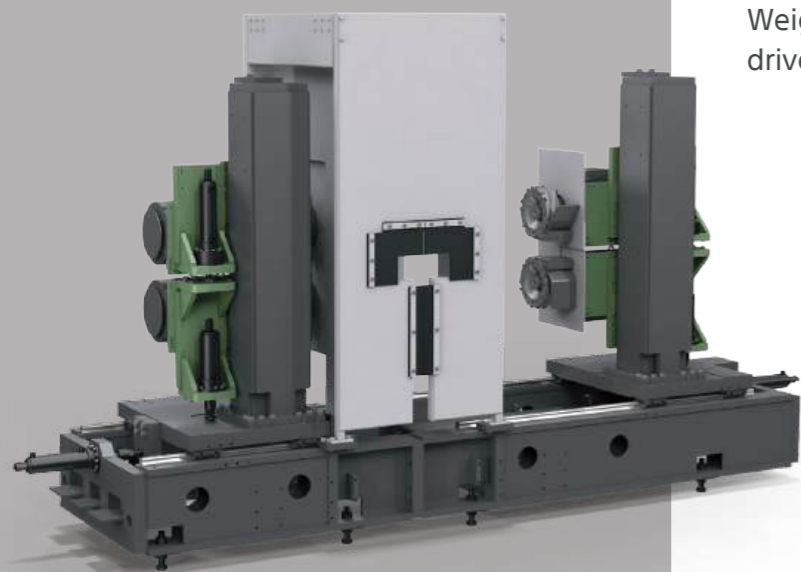

EDGER OPTIMIZER TECHNOLOGY

FR15 M Profiling unit



→ For fixed side boards or one-sided profiling

The profiling unit FR 15 M does profiling of 1 side-board on either side of a cant, with fix board width and variable board position for units with 2 +2 profiling heads.

Depending on the cutting pattern, single sided profiling is also possible.

The profiler heads have a fixed distance according to the set-up of the machine and use a common servo-hydraulic height adjustment.

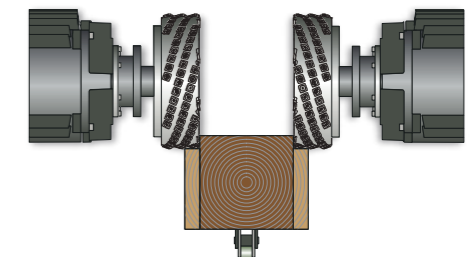
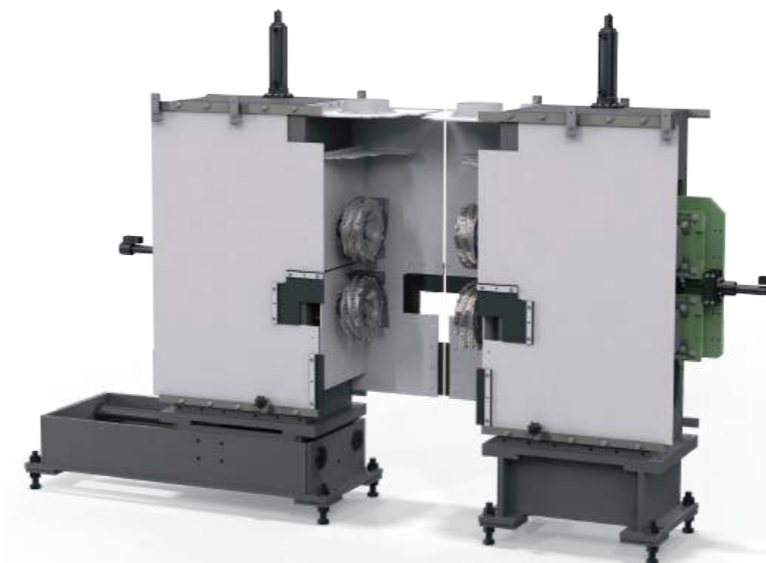

TECHNICAL DATA

profil board width	mm	70-225
Board width unedged	mm	70-225
Feed speed max.	m/min	20-100
Saw arbors drive	kw	37-50
Weight with 4 drive motors approx.	t	8.0

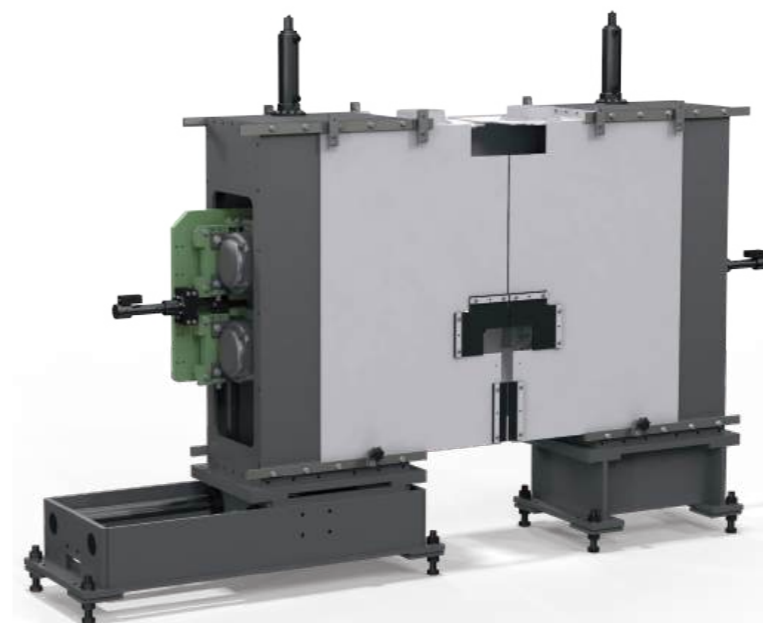

EDGER OPTIMIZER TECHNOLOGY

PF 19 Chipper canter

The chipper canter PF 19 is used for chipping of two parallel faces on the cant and for chipping waney edges on boards of 38mm thickness and higher.

The width adjustment of the chipper head supports is done by servo-hydraulic networks.

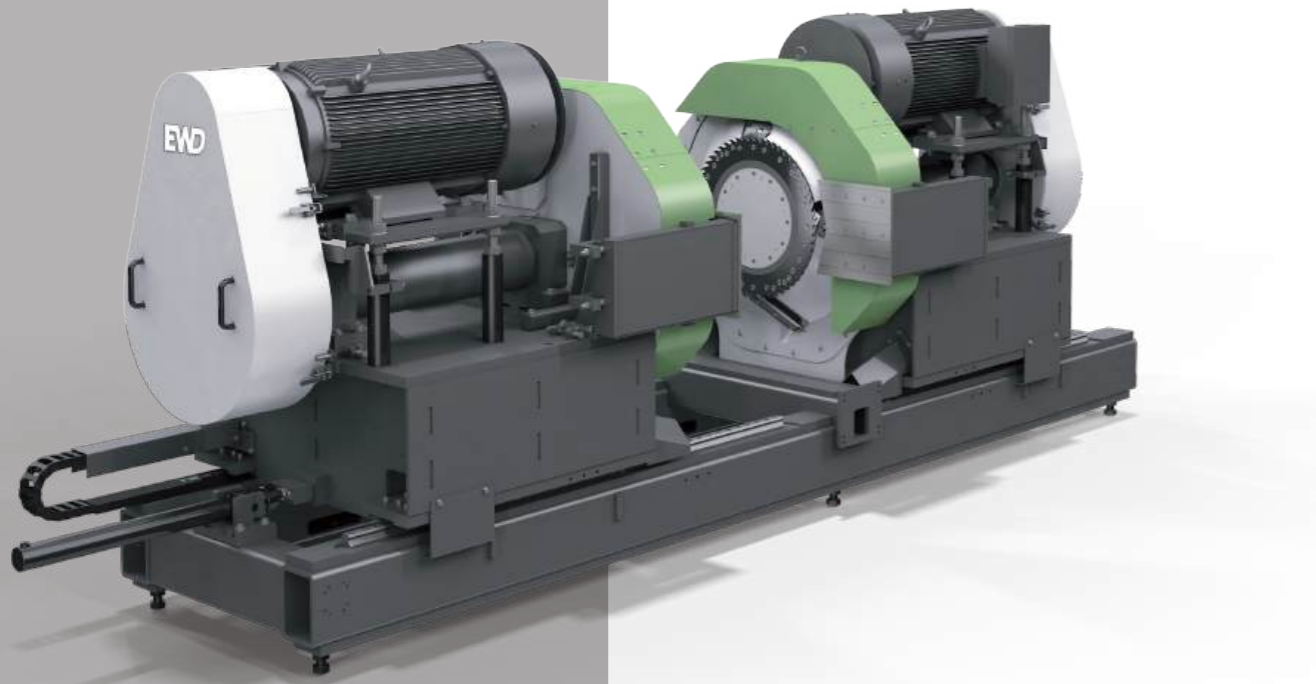

The produced chips meet the high quality requirements of the pulp industry.

The chipper head revolutions are controlled by frequency converter as a function of feed speed and desired chip lengths, within the limits of the chipping tools

CHIPPER HEAD

Straight knives / Spiral knives

Optionally, the chipper canter PF 19 can be fitted with either straight knives, spiral knives or stepped knives heads.

The different head types are matched by the number of tools installed to the desired speed range.

All heads are fitted with either pre- or post sawing circular saw rings, depending on the purpose.

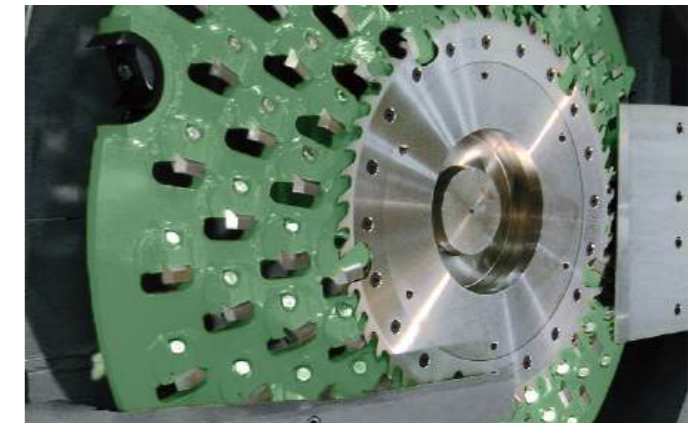

TECHNICAL DATA PF 19

Chipper head diameter		
Straight knives chipper head	mm	1240
Spiral knives chipper head	mm	1260
No. of main knives (straight knives head)	pcs.	3, 4, 6
No. of spirals (spiral knives head)	pcs.	3, 4, 5
Chipping depth per head max.		
Straight knives chipper head	mm	190
Spiral knives chipper head	mm	180
Distance between the chipper heads in operation	mm	60–700
Opening side for tool change	mm	900
Feed speed	m/min.	20–150
Drive power	kW	2x75 - 2x250
Weight with drive motors (2x250kW)	t	13.0





eWood is a comprehensive optimisation and application software from EWD. All modern EWD sawlines and machines share the same eWood user interface.

The interface man – machine offers an intuitive and consistent user concept, allowing effective use of the functions after just a short training period.

- Most modern measuring technology
- Professional optimization and application software

In addition to solid and time-proven mechanical engineering, efficient system controls are essential prerequisites for the high efficiency and yield of the EWD technology.

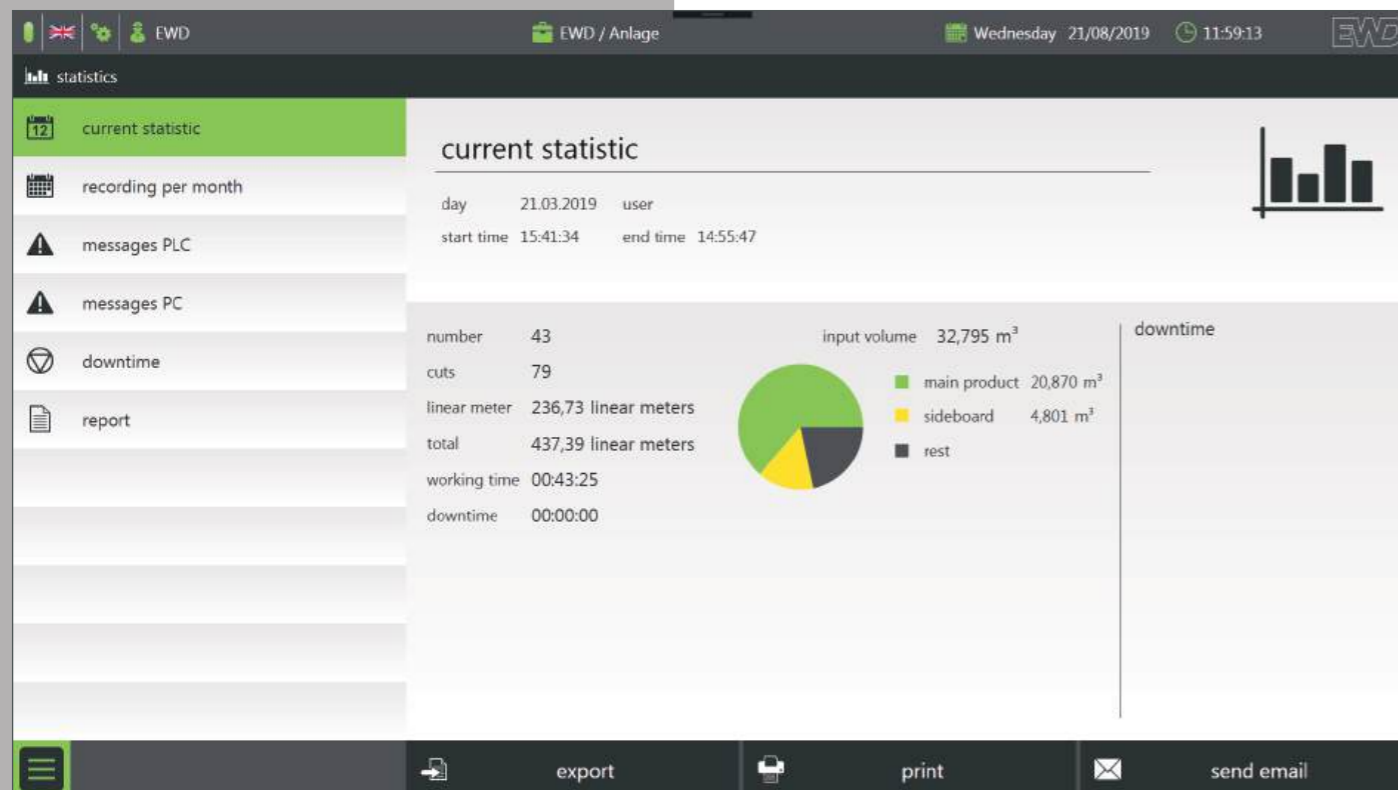

Edit order

customer: Mustermann
priority: 0
comment: []

date of creation: 11/03/2019 16:30:04 author: EWD
last change: 29/03/2019 10:37:49 changed by: EWD

active	name	product	thickness	width	length	MP	SB	short	target	prio	qual	actual	status	nominal	criterion	installation	comment
<input checked="" type="checkbox"/>	22x100	22x100	22	100	2000-6300 (100)	<input checked="" type="checkbox"/>	<input checked="" type="checkbox"/>	-	0	A	13	<input type="text" value="0"/>	<input type="text" value="0"/>	0	number		
<input checked="" type="checkbox"/>	50x100	50x100	50	100	2000-4000 (100)	<input checked="" type="checkbox"/>	<input checked="" type="checkbox"/>	-	0	A	0	<input type="text" value="0"/>	<input type="text" value="0"/>	0	number		
<input checked="" type="checkbox"/>	28x120	28x120	28	120	2000-6000 (100)	<input checked="" type="checkbox"/>	<input checked="" type="checkbox"/>	-	0	A	5	<input type="text" value="0"/>	<input type="text" value="0"/>	0	number		

Edging programs

ID	name	alignemnt	target	number	comment
1	22er	optimal	0	4	
2	255x56+80	optimal	0	0	
3	160x100-250	optimal	0	5	

date of creation: 06.07.2018
time of creation: 16:08:03
author: EWD
last change: 21.08.2019

Products

thickness	width	thickness	width	length	name	product type	lumber species	M. Valu
22	95	22	100	2000-6300 (100)	22x100			£70.00
28	100	22	100	3000	22x100			£100.00
32		22	100	4000	22x100			£100.00
34								
48								
50								
60								
65								
70								
75								



EWD

Esterer WD GmbH
Estererstraße 12
D - 84503 Altötting

T +49 8671 503 0
F +49 8671 503 386

Markwiesenstraße 40
D - 72770 Reutlingen

T +49 7121 5665 0
F +49 7121 5665 400

info@ewd.de