



Technical data

PROFILING AND SAW UNIT FR 15 V

Technical data FR 15 V

Log/cant length min.	m	2.4
Drive power profiling heads	kW	2x75-132
Weight with drive motors	t	16
Machine opening tool change	mm	950
Feed speed max.	m/min	150

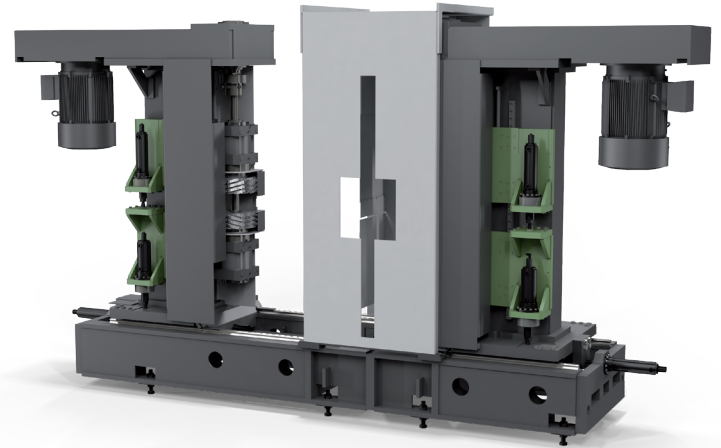

Tools - setting distances FR 15 V

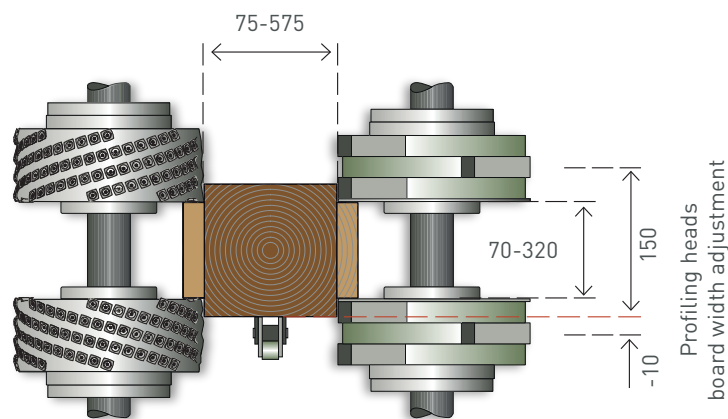

As a result of constant improvement and further development of our designs, the information and illustrations in this brochure are not binding.